

Leviat[®]
A CRH COMPANY

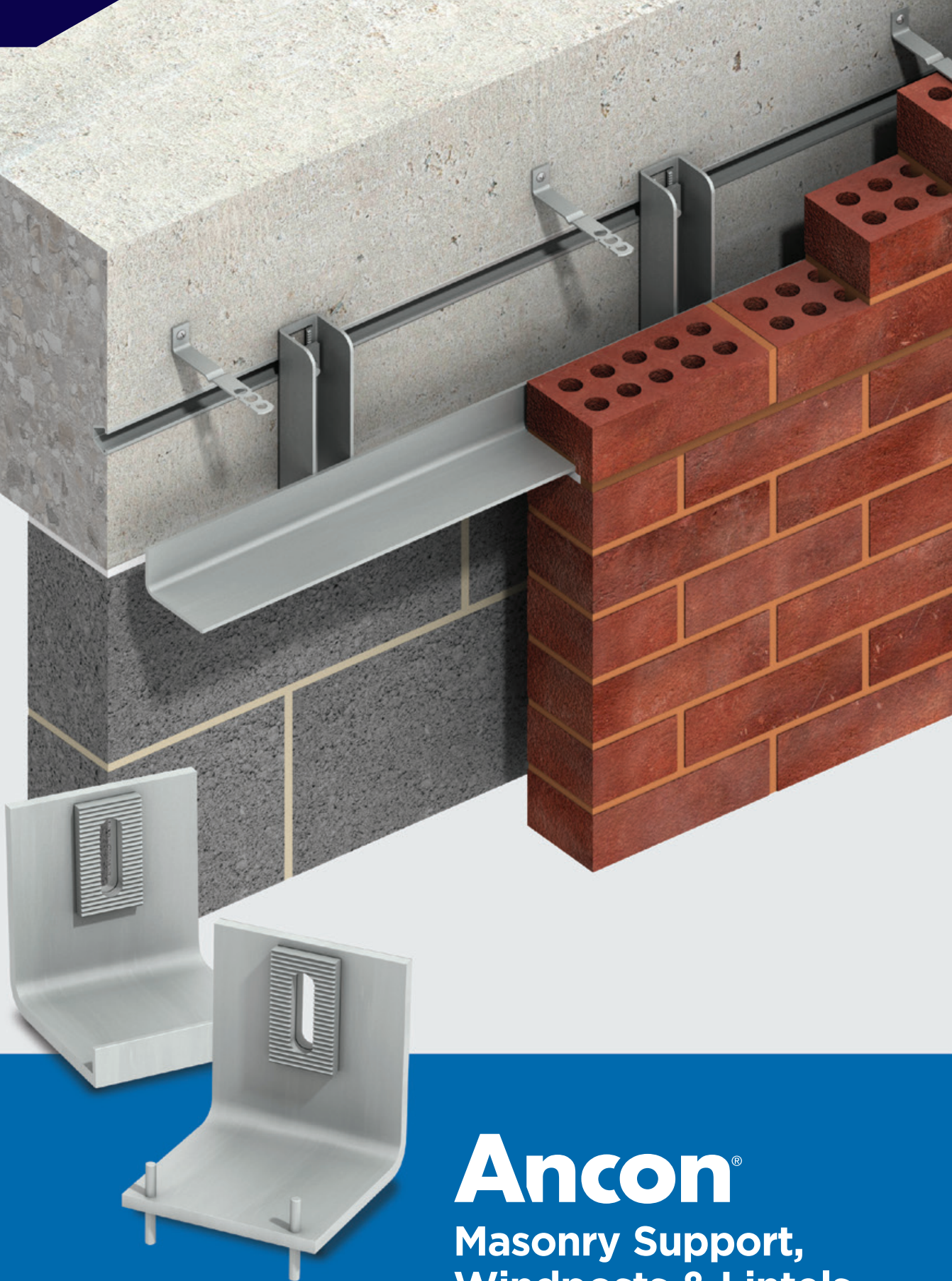

Ancon[®]
**Masonry Support,
Windposts & Lintels**
for the Construction Industry



We are one team. **We are Leviat.**

Leviat is the new name of CRH's construction accessories companies worldwide.

Under the Leviat brand, we are uniting the expertise, skills and resources of Ancon and its sister companies to create a world leader in fixing, connecting and anchoring technology.

The products you know and trust will remain an integral part of Leviat's comprehensive brand and product portfolio. As Leviat, we can offer you an extended range of specialist products and services, greater technical expertise, a larger and more agile supply chain and better, faster innovation.

By bringing together CRH's construction accessories family as one global organisation, we are better equipped to meet the needs of our customers, and the demands of construction projects, of any scale, anywhere in the world.

This is an exciting change. Join us on our journey.

Read more about Leviat at [Leviat.com](https://www.leviat.com)



Our product brands include:

Ancon[®]

Connolly

HALFEN

HELIFIX

ISEDIO

PLAKA



60

locations

sales in
30+
countries

3000

people worldwide

Imagine. Model. Make.

Leviat.com

Masonry Support Systems, Windposts and Lintels

Masonry cladding on concrete or steel framed structures is normally supported by shelf angle support systems.

Frame type, differential movement, type of cladding, masonry load and cavity width all need to be considered when designing the most appropriate fixing solution.



Contents

Introduction to Masonry Support Systems	6	CFA Support System	14-15
Introduction to Windposts and Lintels	7	Individual Brackets	16-17
Design Considerations	8	Stonework Support	18-21
Tolerances	9	Lintels	22-26
MDC Support System	10-11	Windposts and Parapet Posts	27-31
Fixing to Concrete Frames	12	Channel and Bolt Fixings	32
Fixing to Steel Frames	13	Other Ancon Products	33



Masonry Support, Windposts & Lintels

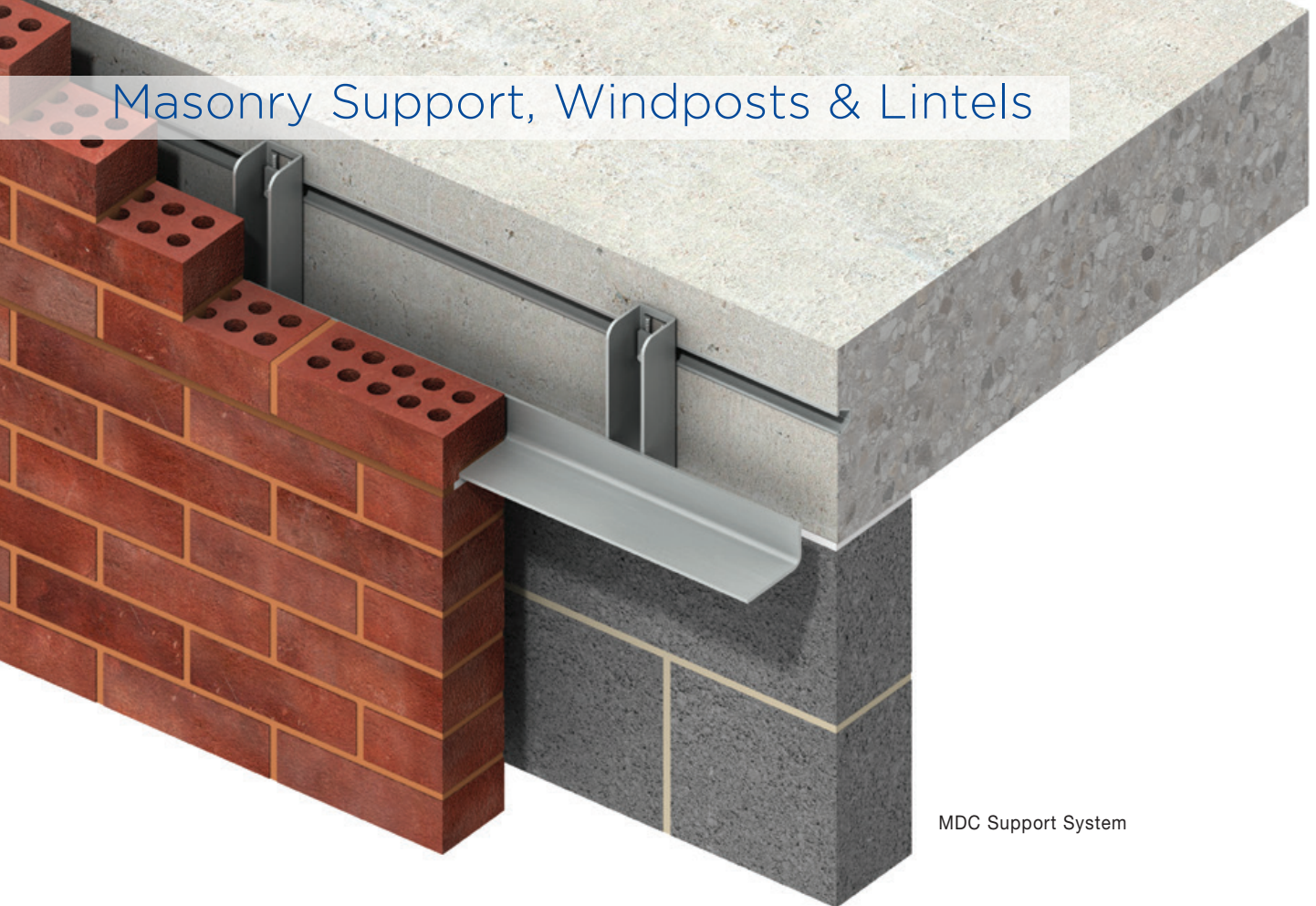

MDC Support System

Masonry Support Systems

Structures with brick or stone cladding will usually necessitate the use of a stainless steel support system for the masonry.

Bracket Angle Support Systems

Ancon MDC Systems have welded brackets and are designed to suit specific applications. They are available in various configurations and are ideal for supporting runs of masonry and special masonry features. Material content is optimised to ensure the most economic solution is designed (pages 10-11).

Continuous Angle Support System

Ancon CFA Systems are mainly used where cavities are small or there is a requirement for the cavity to be closed at the support position (pages 14-15).

Individual Bracket Support System

Ancon Individual Brackets provide great flexibility in design. They are ideal for the support of brickwork curved on plan (pages 16-17).

Stonework Support

Natural stone cladding is often a combination of large individually-sized stones and requires particular attention. Ancon MDC/S Stonework Supports can be designed in a variety of configurations to suit the particular application (pages 18-21).

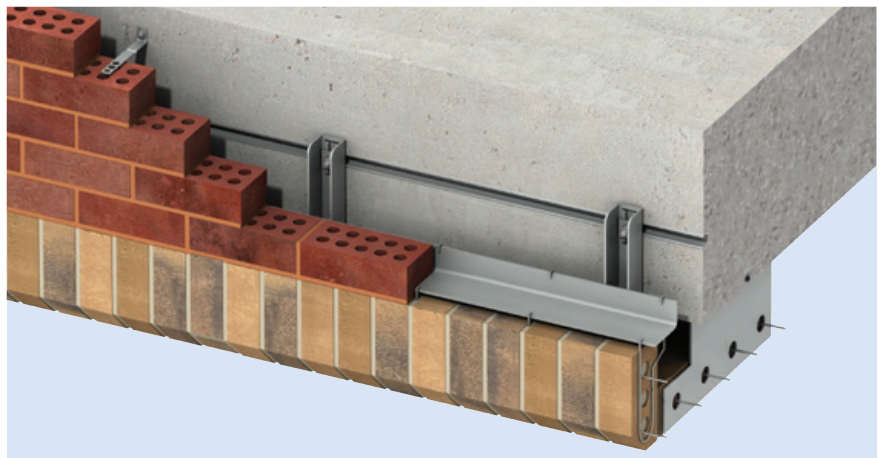

MDC Support System with Stirrups



MDC/SD Stonework Support System

Lintels

Ancon Lintels are manufactured from galvanised or stainless steel. The Housing and Unilintel ranges are designed to suit the light to heavy duty loading conditions found in the majority of residential and commercial buildings (pages 22-25).

Special lintels can be manufactured to suit architectural features and wall constructions not covered by the standard range (page 26).

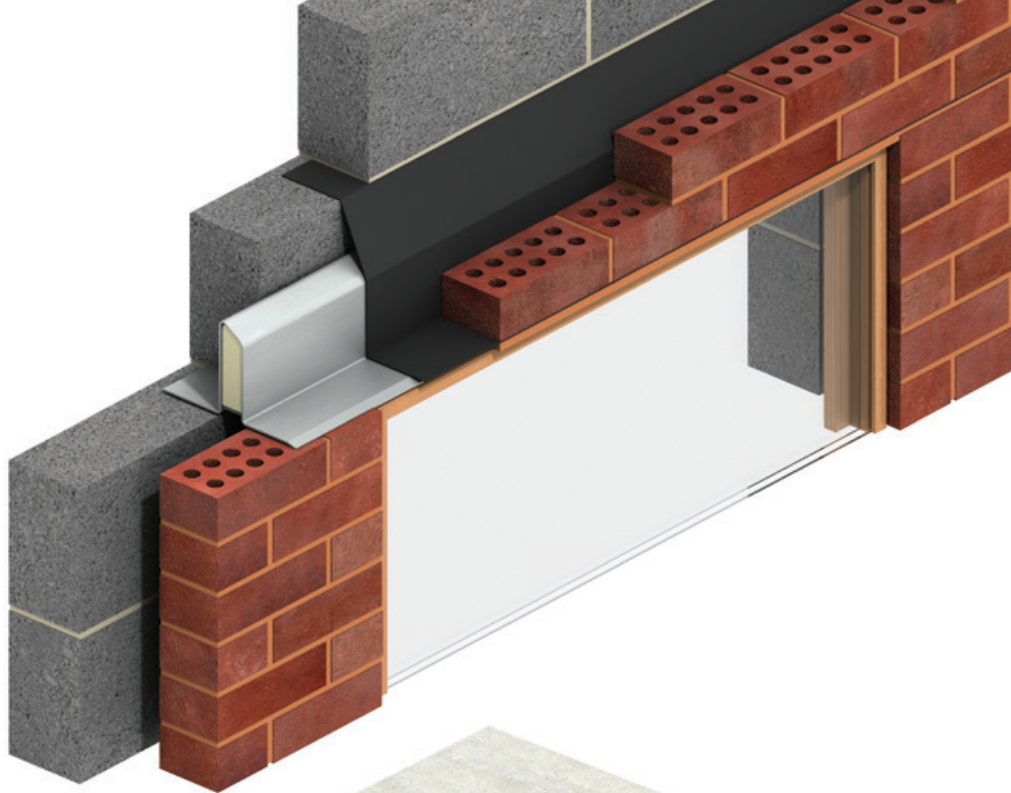

Housing Lintel

Windposts & Parapet Posts

Leviat Windposts span vertically between floors to provide additional lateral support for large panels of masonry or panels with openings.

Parapet posts are used as vertical support for brickwork in either parapet or spandrel panels.

Ancon Windposts and Parapet Posts are designed to suit specific applications (pages 27-31).



Other Products & Services

Leviat also manufactures Wall Ties and Masonry Reinforcement. Free of charge technical services include advice on product selection and CAD details. Contact us for further information.

At the end of a long service life, a stainless steel product is 100% recyclable.



Stainless steel typically contains 60% recycled material.

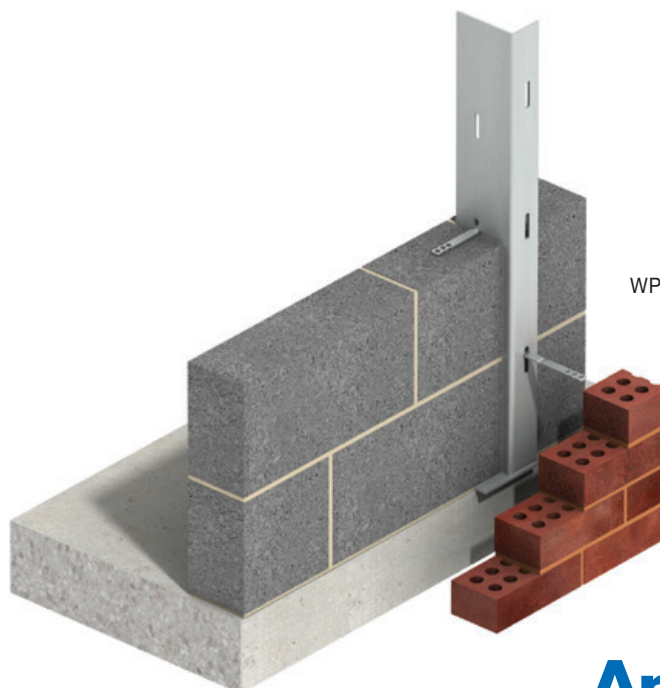

WP2 Windpost

Masonry Support, Windposts & Lintels

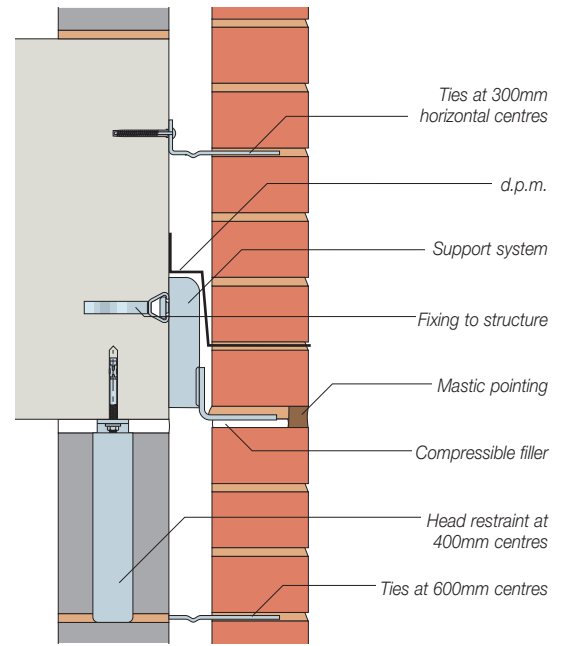
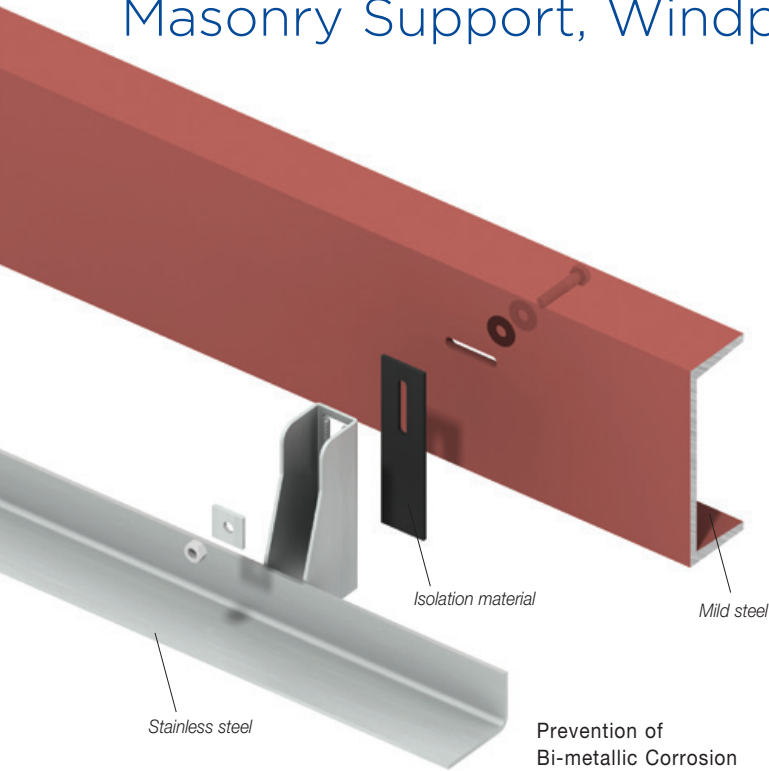

Typical Support Detail

Design Considerations

Structures with brick or stone cladding will usually necessitate the use of stainless steel support for the masonry over horizontal movement joints. Differential movement, corrosion resistance, type of cladding and frame type, all need to be considered.

Differential Movement

The maximum size of a masonry panel should be restricted to limit the effects of differential movement. This is particularly important if clay brickwork is used with concrete blockwork and a concrete frame. The outer leaf of buildings not exceeding four storeys or 12 metres in height, whichever is less, may be uninterrupted for its full height. For other buildings, BS 5628 : Part 1 which, since the withdrawal of this British Standard, remains best practice, requires the outer leaf to be supported at intervals of not more than 9 metres or three storeys, whichever is less. To allow for a vertical movement of around 1mm per metre, movement joints are generally positioned at every storey or every second storey. They are also incorporated in many buildings of less than four storeys or 12 metres in height.

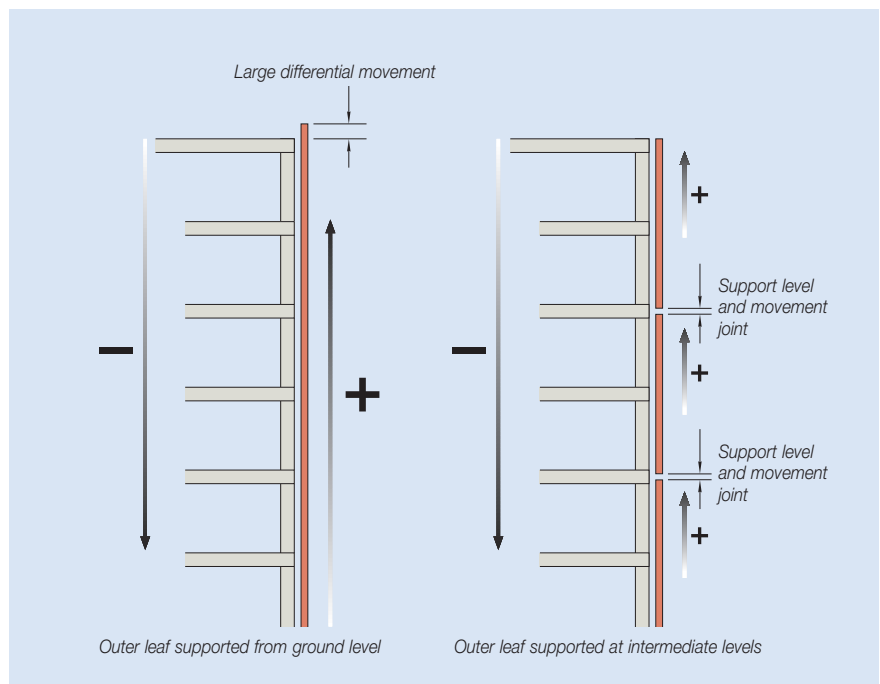

Differential Movement Between Masonry Cladding and Frame

Horizontal Movement Joints

The support will be positioned directly over the horizontal movement joint. The joint will often incorporate a compressible filler and should be of sufficient size to allow for expansion of the masonry below and any shrinkage or deflection of the structural frame. The underside of the support system should be positioned around 2mm above the joint to allow for the support leg to settle when supporting the brickwork above. The clear joint below should be at least

10mm where there is a single storey height of brickwork below the support system. Where there are two storeys or more of brickwork below the support system, the clear joint should be sufficient to accommodate all expected movements. This may result in clear joints in excess of 10mm. Damp-proofing is normally located at the support position. Wall ties should be incorporated within 300mm above and below the support.

Patent No. 2 249 816
 Adjustment of MDC Support System
 Fixed to Concrete



Tolerances

It is important to select the correct support system to ensure that building tolerances can be accommodated. Adjustment will be required in all three planes.

Ancon brackets have a slot at the back to provide vertical adjustment. A serrated surface prevents any slip. Longitudinal adjustment is provided by an Ancon cast-in channel in concrete structures, or horizontally slotted holes in steel framed structures.

Variations in the structural edge beam can be accommodated by adding shims between the system and the structure, or by increasing the bearing of the brickwork. The maximum thickness of shims should not exceed the outside diameter of the fixing or 16mm, whichever is less.

Corrosion Resistance

Ancon Support Systems are manufactured from grade 1.4301 (304) stainless steel and will be suitable for most building applications. In particularly corrosive environments, or where part of the support will be visible, grade 1.4401 (316) should be considered. Bi-metallic corrosion may occur in a damp environment where the stainless steel support system is bolted to a structural steel frame.

This will not affect the stainless steel, but could slightly increase the corrosion rate of the carbon steel. This can be prevented by excluding moisture from the detail, or by isolating the two dissimilar metals. Isolation patches are available for use with Ancon Support Systems. Further information is given in the Ancon brochure, 'The Use of Stainless Steel in the Construction Industry'.

Manufacturing Tolerances

Unless otherwise agreed, the tolerances applicable to cold formed sections are shown in the table below.

Element	Tolerance
Overall length	±5mm
Thickness	±7.5%
Leg length of angle	±3mm
Angle between legs	±2°
Hole or slot centre	±5mm
Mitred corners	±1°
Bow on either axis	±3mm per metre length

Fixing Methods

There are various methods of fixing Ancon Support Systems to the structure. Cast-in channels with 'T' bolts or site drilled expansion bolts can be used with concrete frames. For steel frames the choice is set screws or Ancon Steelgrip into holes in the steel edge member. A range of suitable fixings is included on page 32. Further information is given on pages 12 and 13, and in the Ancon Channel and Bolt Fixings brochure.

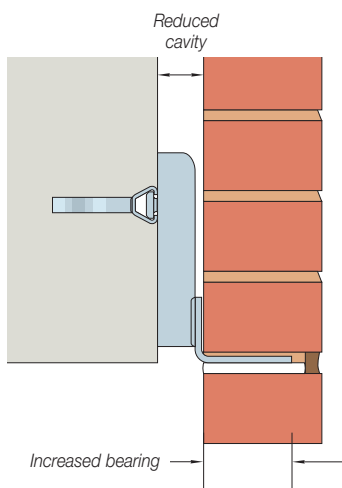

Increased Bearing Used to Accommodate Reduced Cavity

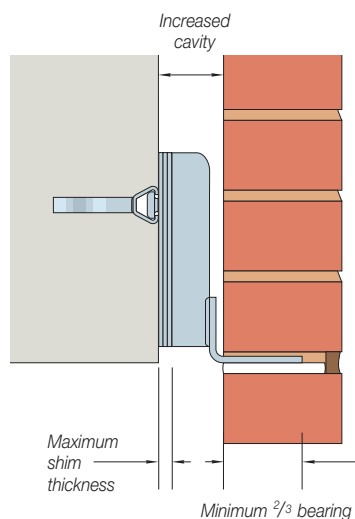

Shims Used to Accommodate Enlarged Cavity

Note: Shims must extend fully to heel of bracket

Masonry Support, Windposts & Lintels

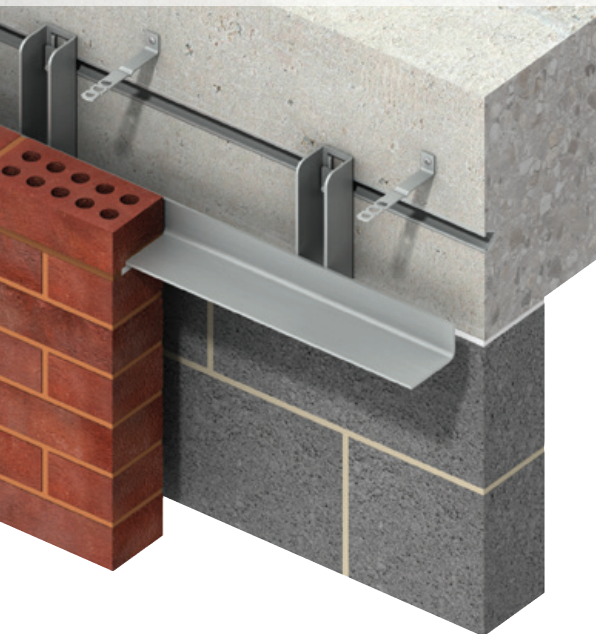

MDC Bracket Angle Support System

Ancon MDC Bracket Angle Support System

Ancon MDC Bracket Angle Support Systems can carry over 8 metres of brickwork and accommodate any width of cavity from 40mm in its standard form. The brackets are welded to the angle and the material content of both components is optimised to ensure the most economic solution is designed.

Design Variations

The Ancon MDC System can be supplied in a variety of configurations to suit particular applications and support special masonry features. The size of the support angle can be varied to suit the thickness and height of the masonry to be carried. Bracket spacing, depth and height are all varied to suit loadings, fixing position and cavity width.

There are several variations of the standard MDC System. MDC/P has the bracket projecting below the structure, MDC/R has a reversed angle welded to the bracket, and MDC/I is a specially inverted system with the support angle at the top of the bracket. These variations allow the support leg of the angle to be positioned anywhere from the top of the bracket to a position below the bottom of the bracket.

Soldier courses can be suspended from MDC systems by using stirrups at 255mm centres. The stirrups fit over the angle and stitching rods span between the stirrups, supporting cored or holed bricks.

The Ancon MDC system can be supplied with extra components to suit the application e.g. closer plates, expanded metal etc.

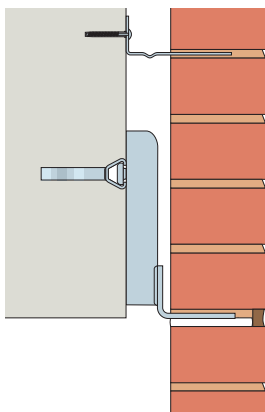

Standard MDC Support System

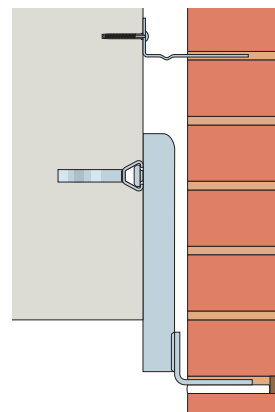

MDC/P Support System

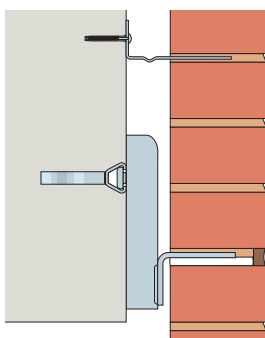

MDC/R Support System

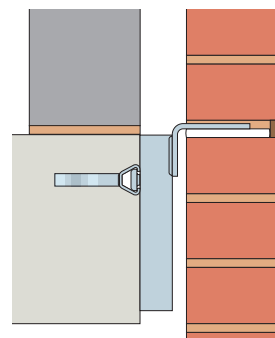

MDC/I Support System

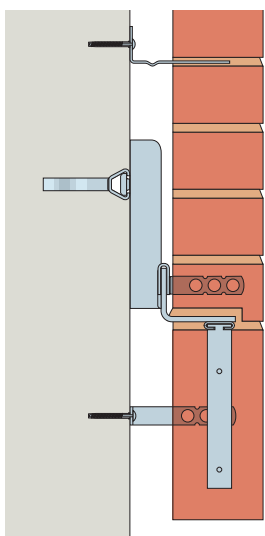

MDC with 36/8 Channel and Hangers Supporting a Soldier Course

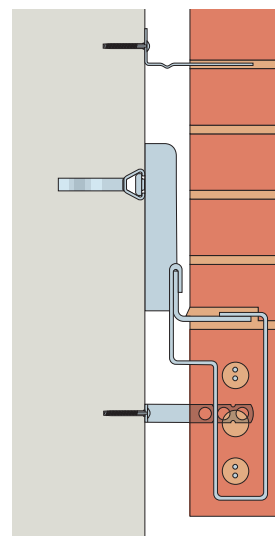

MDC with Stirrups Supporting a Soldier Course

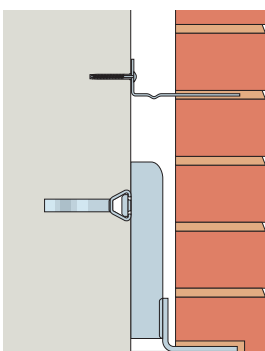

MDC with Closer Plate Welded to Underside

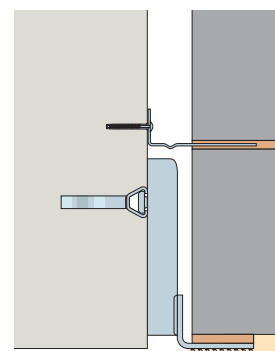

MDC with Expanded Metal Welded to Underside

Setting Out

We can provide drawings showing the location of the fixings (cast-in channels for concrete frames, bolt positions for steel frames). Bracket angle units will be referenced and scheduled and all details submitted for approval before manufacture.

Details for Specification and Ordering

Ancon MDC Systems are tailored to suit each contract, and are based on the cavity size at the support and the masonry load to be carried. We will design an economical configuration of channel, bracket and angle. Specification is as follows:-

MDC / type / cavity / masonry load

e.g. MDC / R / 50 / 6.6

We will design a system with a reversed angle to suit a 50mm cavity and carry 6.6 kN/metre run of masonry.

References

MDC Standard system

MDC/R System with reversed angle

MDC/I Inverted system

Some applications demand that the support leg is below the soffit of the structure. Where this is no more than 150mm, this can be specified as a suffix to the standard reference by **P projection**.

MDC / cavity / masonry load / projection

e.g. MDC / 50 / 6.6 / P 75

We will design a standard system to suit a 50mm cavity, carry 6.6kN/m, with a bracket projection of 75mm.



MDC/R Support System

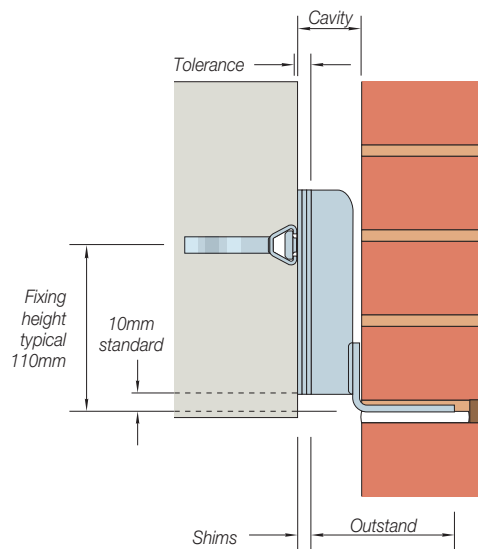

MDC Support System with Shims

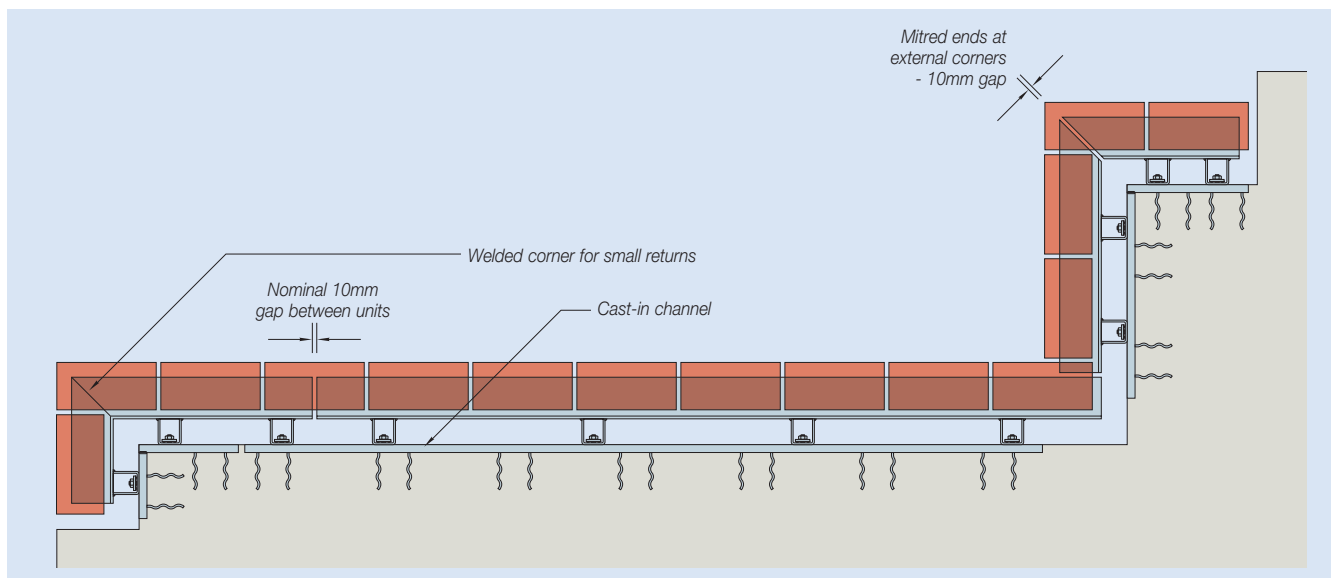

Typical Layout of MDC Support System

Masonry Support, Windposts & Lintels

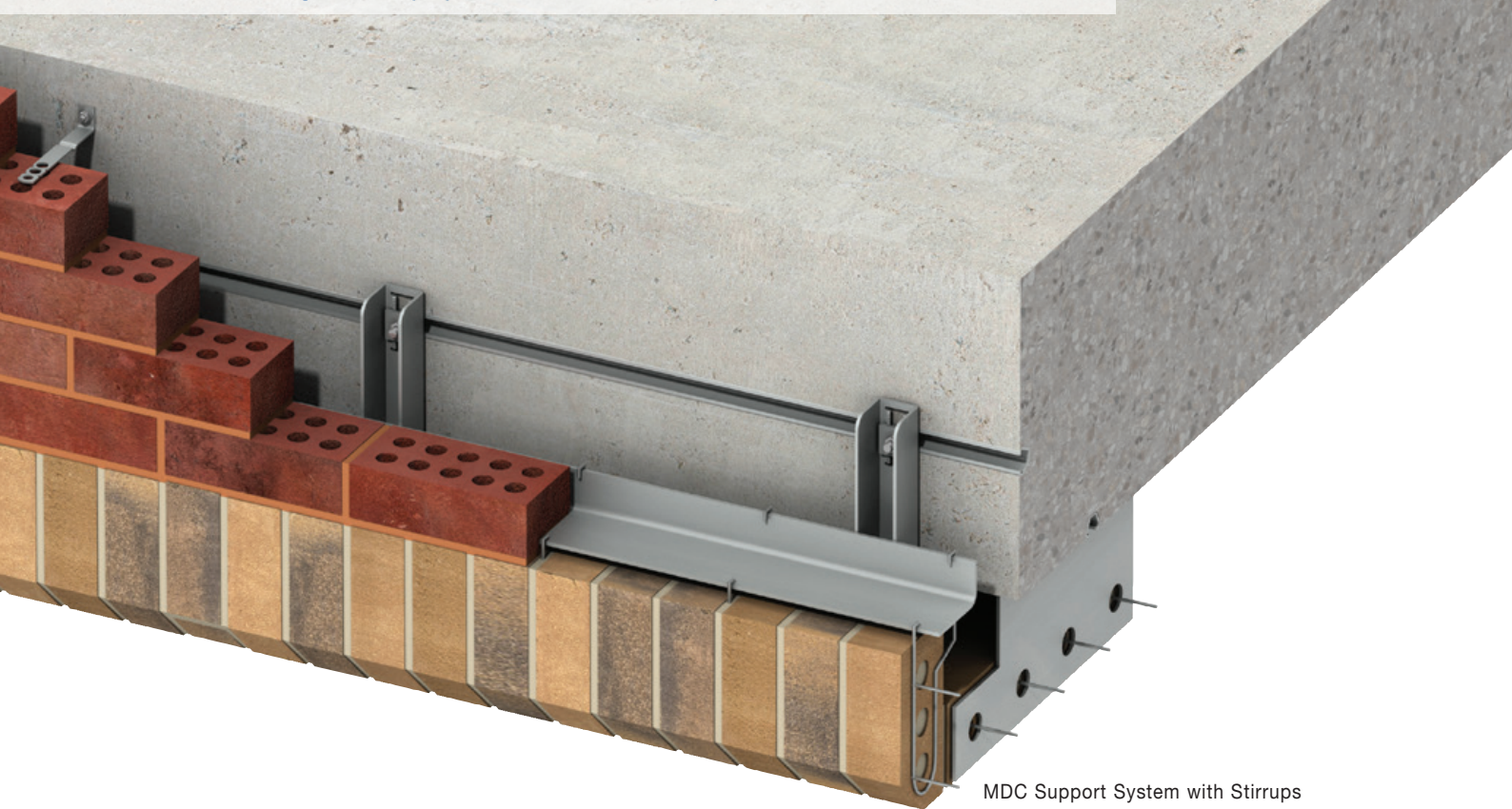

MDC Support System with Stirrups fixed to 30/20 Cast-in Channel

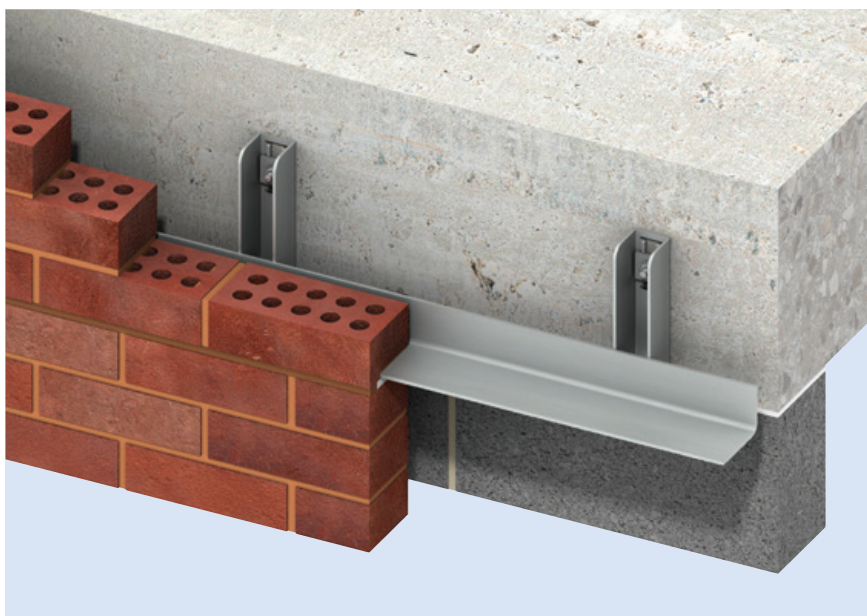

MDC Support System fixed with Single Expansion Bolts

Concrete Frames

Ancon Masonry Support Systems are generally fixed to Ancon 30/20 Channels cast into the edge of the concrete. For applications where particularly high loads are involved Ancon 40/25 Channel may need to be considered. Details of these channels are shown on page 32. The use of cast-in channels allows the support system to be fixed to the structure with 'T' bolts and moved along the line of the channel into the correct position. The slot in the back of the bracket allows vertical adjustment. This permits greater freedom in the positioning of the cast-in channel to avoid horizontal reinforcement.

As an alternative, Ancon Expansion or Resin Bolts can be used when cast-in channels have not been included in the edge beam.

Steel Frames

Ancon Support Systems can be fixed directly to uncased structural steel frames. The fixing positions can usually be at constant centres to simplify the fabrication of the steelwork.

For cavities larger than 75mm there may be a requirement for additional fixings near external corners. **When fixing any Ancon System horizontal slots should be provided in the steel edge beam stiffeners to allow lateral tolerance.**

If excessive movement of the support system is to be avoided, the structural edge member must be designed to minimise deflections and accommodate the torsional forces created by the eccentric load from the brickwork.

Ancon Support Systems can be fixed to Rolled Hollow Sections using Ancon Steelgrip fixings. These fixings are designed for use where access is only available from one side.

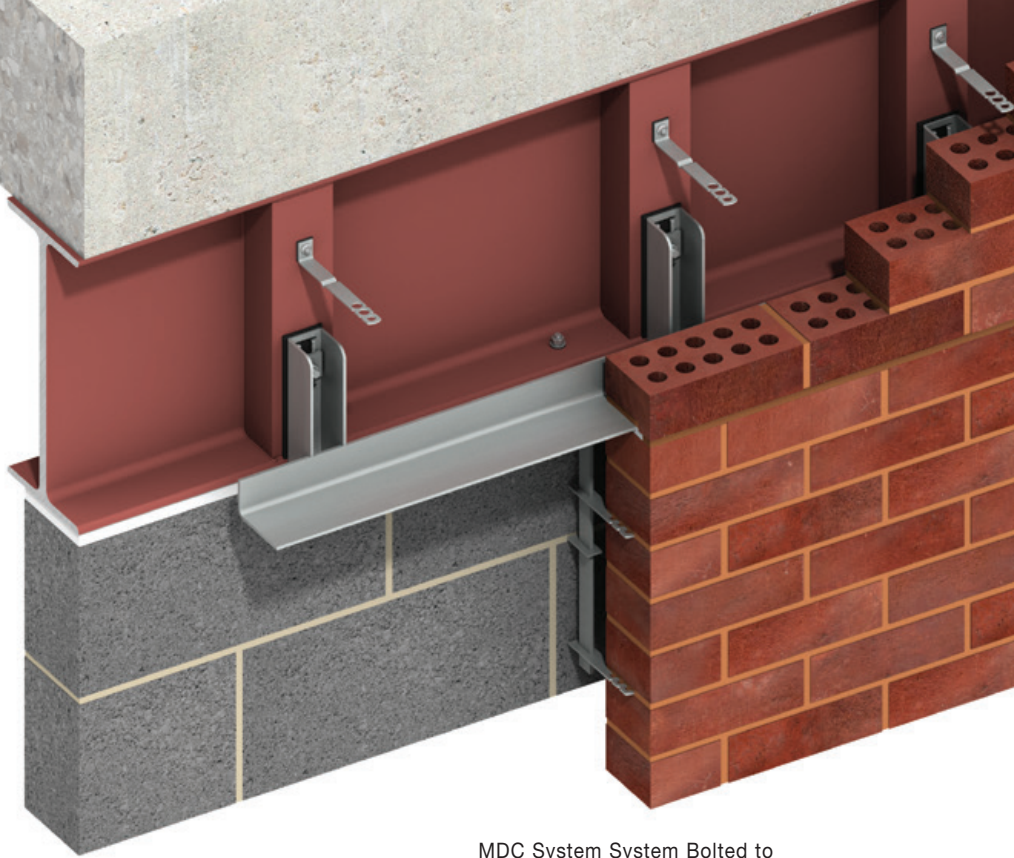

MDC System System Bolted to Steel Edge Beam Stiffeners

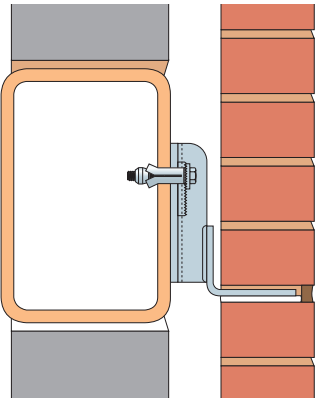

MDC Support System fixed to face of RHS using Ancon Steelgrip

Ancon MDC/TC Top Cleat System can be employed to fix directly to the top of a concrete beam using expansion bolts.

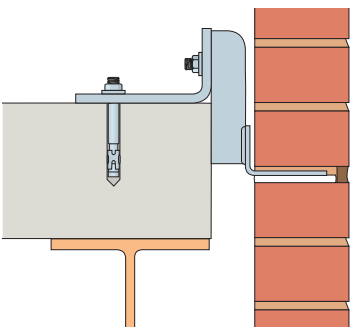

MDC/TC Support System incorporating individual Top Cleat and Expansion Bolt

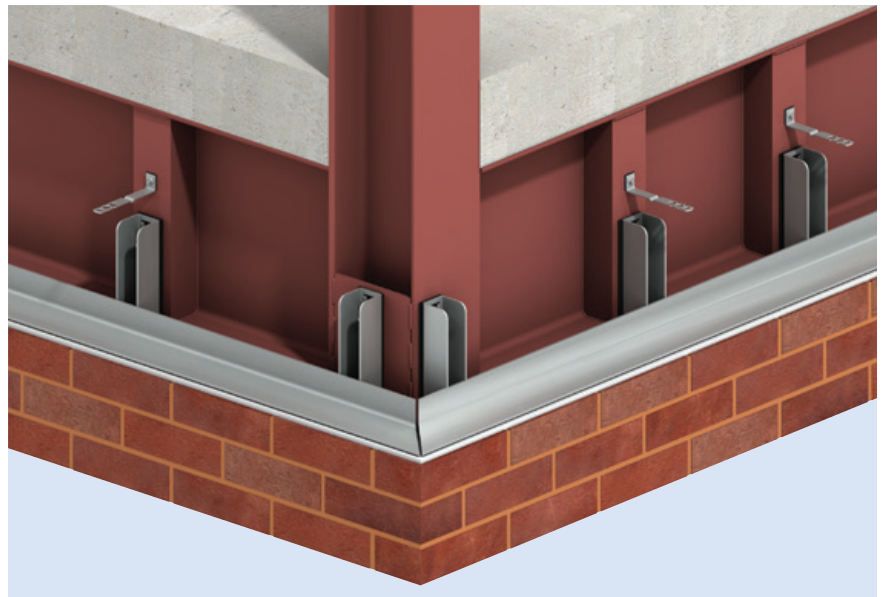

MDC Support System Bolted to Steel Edge Beam Stiffeners and a Corner Column

Bi-metallic Contact

Corrosion of the steel frame may be slightly increased where there is direct contact with stainless steel in a damp environment. This will not affect the stainless steel and can be avoided by isolating the two dissimilar metals. This can be achieved by painting the contact area or by incorporating a separating membrane that can be supplied with the Ancon Support System. For further information see pages 8-9.

Masonry Support, Windposts & Lintels



CFA Support System Fixed to 30/20 Channel

Ancon CFA Continuous Angle Support System

Ancon CFA Systems can carry over 8 metres of brickwork and accommodate various cavity widths. For many applications, particularly where large cavities are involved, the Ancon MDC Support System may prove to be a more economical solution. Continuous angles are more suitable for applications where cavities are small or there is a requirement for the cavity to be closed at the support position. The angles are cold formed and will normally be supplied in lengths of up to 4 metres.

Design Variations

In addition to variations in angle size and thickness, an inverted version, the CFA/I, has the support leg at the top and the fixing slots positioned closer to the corner of the angle.

Steel Frames

Ancon CFA Support Systems can be fixed directly to uncased structural steel frames. Universal beams will require an angle to be welded between the flanges at each bracket position. **Horizontal slots should always be provided in the steel edge beam to allow lateral tolerance.** The angle will have vertical slots with serrated pads welded to the angle.

The structural edge member must be designed to minimise deflections and accommodate the torsional forces created by the eccentric load from the brickwork, if excessive movement of the support system is to be avoided.

Concrete Frames

The CFA System can be fixed to cast-in channels or with expansion bolts. The support angle will either be provided with horizontal slots to suit AnconLock Toothed Channels or with vertical slots and serrated pads to suit continuous channels cast horizontally. For further information see page 32.

Adjustment

Adjustment is provided in every direction to allow for tolerance in the structural frame. Vertical slots in the angle with serrated pads allow $\pm 25\text{mm}$ adjustment. Horizontal adjustment is virtually unlimited when fixing to a continuous cast-in channel and will depend on the length of the slotted holes in the edge member when fixing to steel.

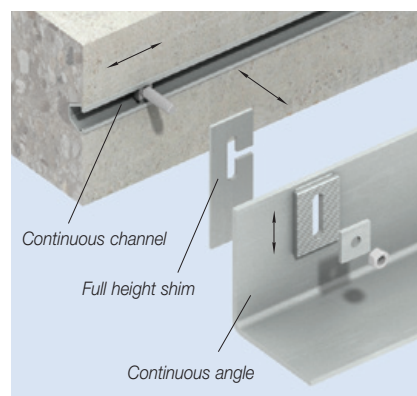

The serrated lips of the AnconLock Channel permit a vertical adjustment of up to $\pm 28\text{mm}$. Slotted holes ($18 \times 60\text{mm}$) in the angle allow horizontal adjustment of $\pm 22\text{mm}$. Shims can be included between the bracket and the frame up to a maximum thickness of the outside diameter of the fixing bolt, or 16mm whichever is less.

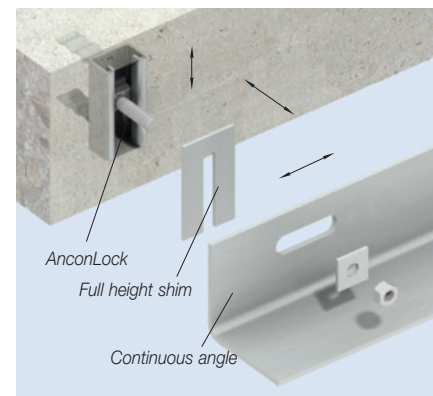

Bi-metallic Contact

Corrosion of the steel frame may be slightly increased where there is direct contact with stainless steel in a damp environment. This will not affect the stainless steel and can be avoided by isolating the two dissimilar metals. This can be achieved by painting the contact area or by incorporating a separating membrane that can be supplied with the Ancon CFA Support System. For further information see pages 8-9.

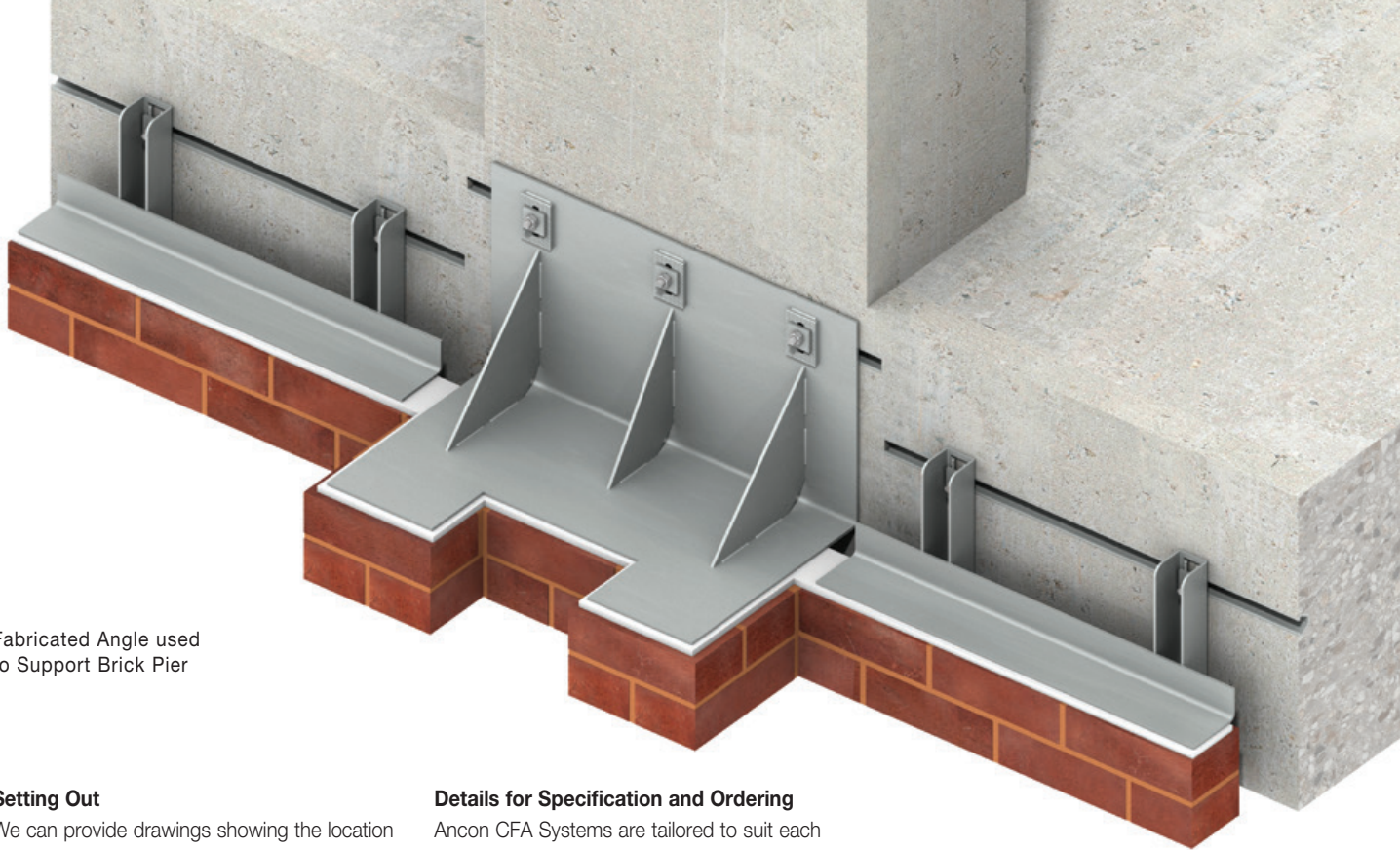

Fabricated Angle used to Support Brick Pier

Setting Out

We can provide drawings showing the location of the fixings (cast-in channels for concrete frames, bolt positions for steel frames). Angle units will be referenced and scheduled and all details submitted for approval before manufacture.

Fabricated Angles

Many features will need special design attention, especially if double skin brickwork is to be supported. Fabricated angles with stiffeners, used in conjunction with the Ancon MDC System for adjacent single skin brickwork, is often the best solution.

Curved Masonry

Curved angles can be supplied for arches or other applications. Where masonry is curved on plan, we can provide either curved angles, individual brackets (pages 16-17) or an MDC System (pages 10-11) in short angle lengths.

Details for Specification and Ordering

Ancon CFA Systems are tailored to suit each job, based on the cavity size at the support and the load to be carried. We will design the most economical system. Specification is as follows:-

CFA / type / cavity / masonry load
e.g. CFA / I / 30 / 6.0

We will design a system with an inverted angle to suit a 30mm cavity and carry 6.0kN/metre run of masonry.



References

- CFA Standard system
- CFA/I Inverted system

Some applications demand that the support leg is below the soffit of the structure. Where this is no more than 75mm, this can be specified as a suffix to the standard reference by **D drop.**

CFA / cavity / masonry load / drop
e.g. CFA / 30 / 5.6 / D 50

We will design a standard system to suit a 30mm cavity, carry 5.6kN/m, with an angle drop of 50mm.

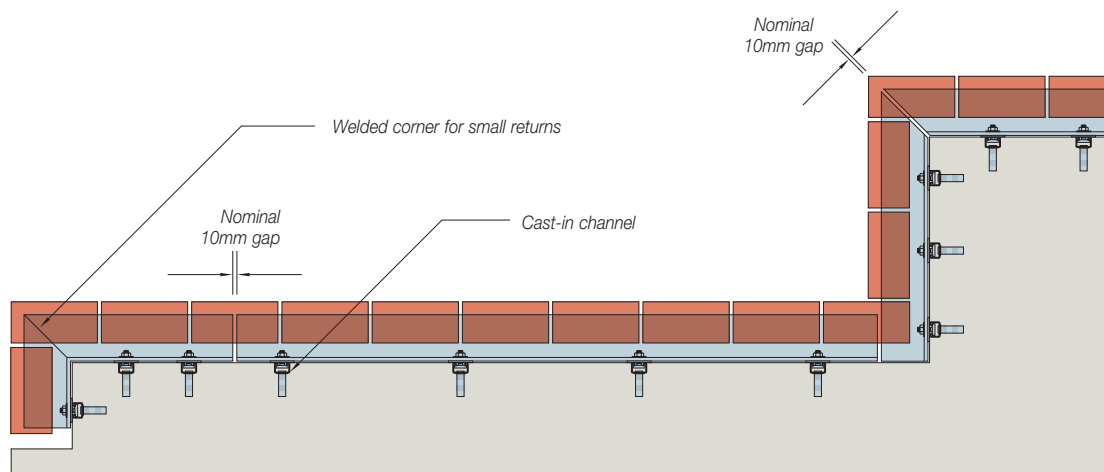

Typical Layout of CFA Support System

Masonry Support, Windposts & Lintels



Feature Brickwork Supported from above by LDB/S Individual Brackets

Ancon Individual Bracket Support System

Three versions of the Ancon Individual Bracket Support System are available, MDB, LDB and AMK. MDB brackets at 255mm centres will carry approximately 8 metres of brickwork and LDB brackets will carry approximately 4 metres.

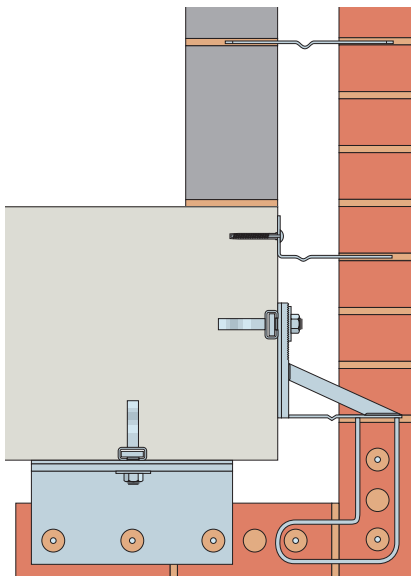

Soffit Support using LDB/S and Soffit Angle

The system comprises individual brackets positioned at each perpend, bolted back to a continuous channel cast into the edge of the concrete. The 4mm thick support plate of the standard bracket can be accommodated within a 10mm bed joint. LDA and MDA angle support brackets will generally be required at vertical movement joints and corners. These brackets have thicknesses of 6mm and 8mm respectively.

Design Variations

Two applications for individual brackets are for the support of soldier courses from above, and for the support of non-structural arched brickwork. Both these applications involve individual brackets at 255mm centres that have stirrups welded to the underside. Stitching rods span the stirrups and support the three bricks between the brackets.

The use of LDB/IS brackets with the stiffener below the support plate provides greater freedom for the brickwork above.

Ancon Soffit Angles are used in conjunction with LDB/S brackets to extend the support of soffit brickwork. These are usually spaced at 255mm centres and fixed to Ancon 28/15 Cast-in Channel.

Adjustment

Adjustment is provided in every direction to allow for tolerance in the structural frame. The serrated and slotted face of the bracket allows for vertical adjustment. Cast-in channel will provide virtually unlimited horizontal adjustment. Shims can be included between the bracket and the frame up to a maximum thickness of the outside diameter of the fixing bolt or 16mm, whichever is less.

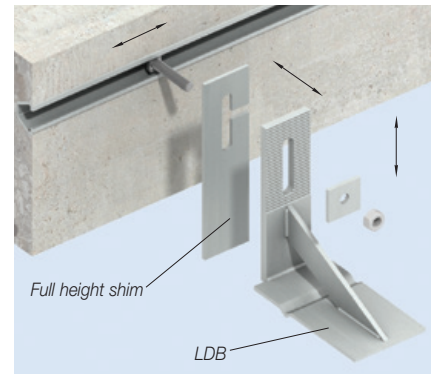

Adjustment of Individual Bracket Support System



Curved Brickwork

Ancon LDBs and MDBs are ideal for supporting brickwork that is curved on plan. As an alternative, special MDA brackets can be designed to suit a wider range of loads and cavity widths. When fixing to concrete, Ancon 28/15, 30/20 or 38/17 channel can be supplied curved to suit the radius or expansion bolts can be used.

Corbelled Brickwork

Individual brackets can be used to support brickwork at the top of the corbel. Ancon SC28 Corbel Ties restrain the corbelled brickwork to 28/15 channel cast into the sloping face of the concrete. LDB/IS can be used to suspend a soldier course over openings.

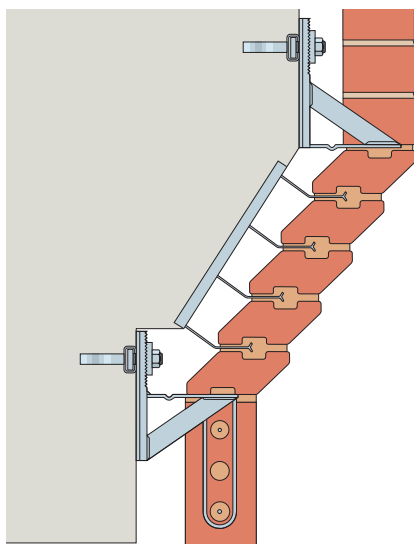

Corbelled Brickwork

References

- LDB Standard bracket with stiffener
- LDA Bracket with angle
- LDB/S Bracket with stirrup
- LDB/IS Bracket with stirrup and the stiffener below
- MDB Standard bracket with stiffener
- MDA Bracket with angle
- AMK Standard bracket

Support to brickwork around external corners may involve special details.

Bracket Reference	SWL/Bracket (kN)	Typical Bolt
LDB/LDA	2.0	M10
MDB/MDA	4.0	M12
AMK 3.5	3.5	M12
AMK 7.0	7.0	M16
AMK 10.5	10.5	M16



Special MDA Brackets Supporting Brickwork Curved on Plan

Setting Out

We can provide drawings showing the location of the cast-in channels. Brackets will be referenced and scheduled, and all details submitted for approval before manufacture.

Details for Specification and Ordering

Ancon Individual Brackets are available to suit most cavity sizes and can be specified as follows:-

Type / cavity / masonry load

e.g. LDB / 50 / 8.0

We will design an LDB system to suit a 50mm cavity and carry 8.0 kN/metre run of masonry.

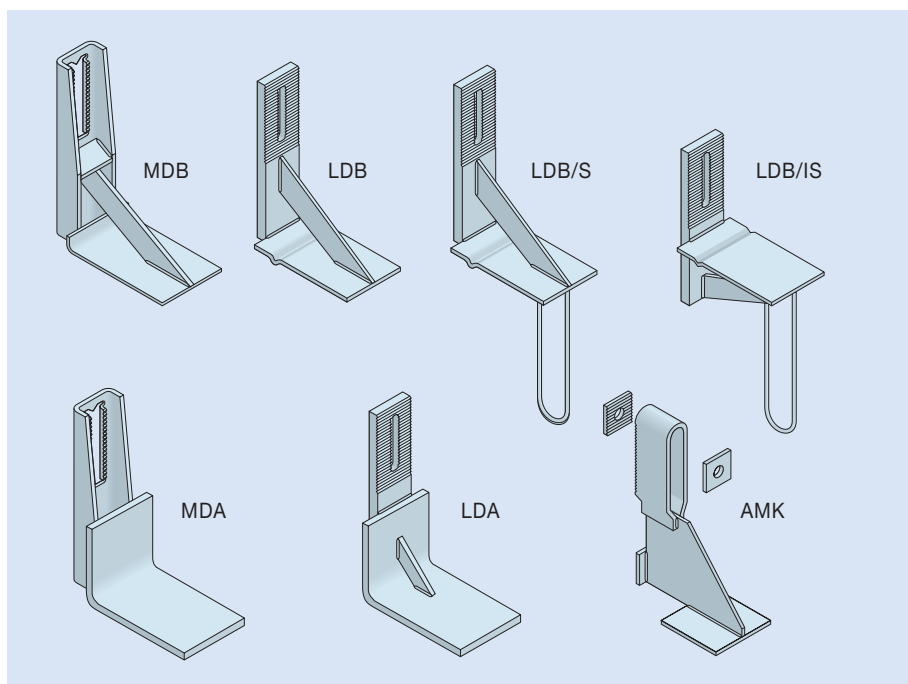

Masonry Support, Windposts & Lintels

Stonework Support

Stone cladding is often a combination of large individually sized stones. These can sometimes vary in thickness and may include cornice or other stones that stand out from the general line of the cladding. Support for the stonework will usually be positioned over the horizontal movement joint at each floor level and over openings.



The most efficient method is for individual corbel supports to be positioned at the vertical joint between two adjacent stones. As an alternative, two smaller supports can be located near each end of each stone. The support of cornice and other particularly large stones will need special attention.

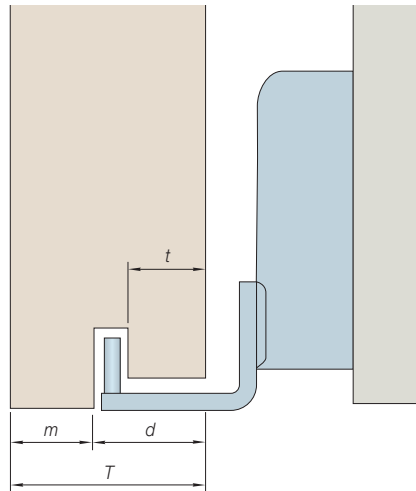

Recommended Minimum Dimensions

Design Considerations

The design of stone cladding should be in accordance with BS 8298 : 1994 Code of practice for the design and installation of natural stone cladding and lining.

The minimum bearing at the support is generally 50% of the thickness of the stone. A single support carrying two stones should be at least 75mm long. Where individual supports are used, these should be at least 50mm long.

Minimum Dimensions for Stonework

Type of Stone	Less than 3.7m above ground including facias				More than 3.7m above ground including facias			
	T (mm)	d (mm)	m (mm)	t (mm)	T (mm)	d (mm)	m (mm)	t (mm)
Granite								
Slate	30	20	7	12	40	25	7	15
White Marble								
Quartzite								
Hard Limestone								
Travertine	30	20	7	12	40	25	7	15
Limestone								
Sandstone	50	25*	20	20*	75	37*	20	30*

Notes: Extract from BS8298: 1994 Code of practice for the design and installation of natural stone cladding and lining.
* T/2 if stone thickness (T) is greater than 75mm



Individual MDC/SC Stonework Support Brackets

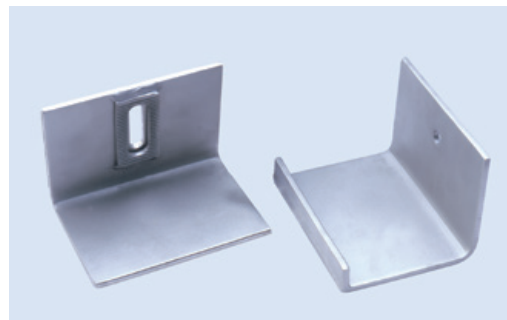

Individual CFA/SC and CFA/SL Stonework Corbel Angles



Ancon CFA/S Stonework Supports

CFA/S Corbel Angles

These are individual angles that accommodate a fixing bolt in the vertical leg. The dimensions are chosen to suit the application. The angles can also be supplied with a lip or dowels to restrain the base of each stone (Ref CFA/SL or CFA/SD).

CFA/SC Corbel Angles

These are similar to the CFA/S, but the bottom leg is inclined at 15° to provide restraint where the support has to be positioned above the base of the stone.

Ancon Corbel Angles are designed to suit each application. The table shows examples of CFA/S and CFA/SC supports. Please contact our Technical Services Team to discuss specific requirements.



Individual CFA/SC Stonework Corbel Angle

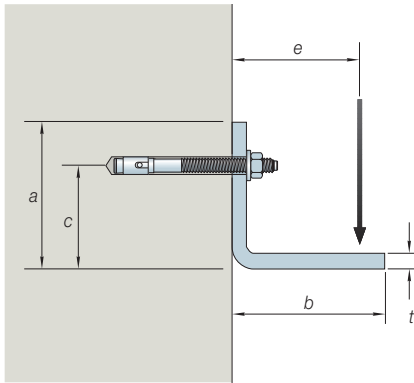

Typical Sizes for CFA/S and CFA/SC Supports 150mm Long

Load Position e (mm)	Thickness t (mm)	Fixing Height c (mm)	Overall Height a (mm)	Outstand b (mm)	SWL (kN)	Fixing Bolt Reference
60	8	70	100	73	3.4	FBNII 12/20 A4-126
	10	70	100	73	5.4	FBNII 12/20 A4-126
80	8	70	100	93	2.5	FBNII 12/20 A4-126
	10	70	100	93	3.9	FBNII 12/20 A4-126
	12	100	130	93	5.8	FBNII 12/20 A4-126
100	8	70	100	113	1.8	FBNII 12/20 A4-126
	10	70	100	113	3.1	FBNII 12/20 A4-126
	12	100	130	113	4.5	FBNII 12/20 A4-126
120	12	100	130	133	3.5	FBNII 12/20 A4-126
	15	120	150	133	5.7	FBNII 12/20 A4-126
140	15	120	150	153	4.3	FBNII 12/20 A4-126

Notes: Recommended fixings assume a minimum edge distance (all directions) of 115mm and a minimum bolt spacing of 230mm. Fixings are based on un-cracked concrete, min. 30MPa. For specific applications please contact us.

References

CFA/S Standard corbel angle

CFA/SC Corbel with angle leg inclined 15°

CFA/SD Corbel angle with dowels

CFA/SL Corbel angle with lip



CFA/S



CFA/SD

Masonry Support, Windposts & Lintels



Full height shim

Adjustment of MDC/S Bracket

MDC/S



Individual MDC/SD Stonework Support Bracket

Ancon MDC/S Stonework Supports

Ancon MDC/S Stonework Supports are based on the MDC masonry support system. The bracket height and depth are varied to suit the cavity size and the loadings. The dimensions of the angle are selected to suit the stonework to be supported.

Design Variations

The MDC/S Stonework Support can be supplied in a variety of configurations to suit the particular application.

Ancon MDC/SD has a dowel to restrain the base of each stone, MDC/SC has the bottom leg of the angle inclined at 15° to provide restraint where the support has to be positioned above the base of the stone.

Adjustment

The serrated and slotted face of the MDC/S bracket allows for vertical adjustment. Cast-in channel will provide horizontal adjustment, but because fixing positions can be difficult to predetermine, expansion bolts are often used. Shims can be included between the bracket and the frame up to a maximum thickness of the outside diameter of the fixing bolt, or 16mm, whichever is less.

Details for Specification and Ordering

Ancon Stonework Supports are generally designed to suit specific contracts. Our technical staff will be pleased to discuss the most appropriate support system. Standard stonework supports may however be specified as follows:-

MDC / type / cavity / stone width / load

e.g. MDC / SD / 50 / 75 / 4

We will design individual MDC/SD supports with dowels to suit 75mm thick stone with a 50mm cavity behind. Each bracket will support a load of 4kN.

References

MDC/S	Standard MDC Stonework Bracket
MDC/SC	Bracket with angle leg inclined 15°
MDC/SD	Bracket with dowels
MDC/SL	Bracket with lip



SSB Stonework Support Bracket



Ancon SSB Support Brackets

The Ancon SSB Bracket supports and restrains stonework with a facing thickness of between 25mm and 40mm. They can be positioned in either the vertical or the horizontal joints and allow adjustment without the need for shims.

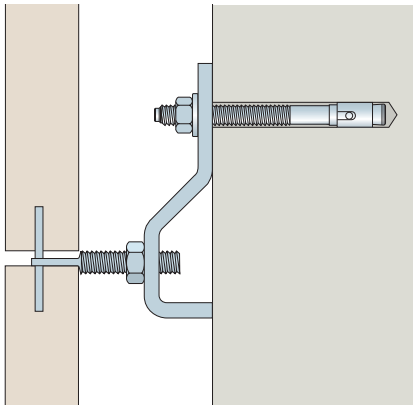

SSB Stonework Support Bracket

Ancon SSB Support Brackets

Reference	Facing Thickness (mm)	Cavity Size (mm)	Adjustment +/- (mm)	Dead Load (N)	Wind Load (N)	Fixing Height (mm)	Fixing Load SWL (N)
SSB-1	25	50	10	450	400	107	736
	30						
	40						
SSB-1a	25	60	10	450	400	107	779
	30						
	40						
SSB-2	25	60	10	850	750	132	1330
	30						
	40						
SSB-2a	25	75	10	850	750	132	1426
	30						
	40						
SSB-2c	25	100	10	700	600	132	1289
	30						
	40						

Ancon ASB Bracket

The ASB is an adjustable bracket for the support of thin stone and rain-screen cladding. It offers exceptional capacity for adjustment without cutting on-site, allowing rapid and accurate installation of stone panels. Vertical adjustment in 1mm increments is provided by the slot in the bracket and the use of shims between the two components of the bracket. These shims are supplied as standard.

Very large cavities of up to 270mm are easily accommodated. The standard ± 20 mm horizontal adjustment can be increased to ± 25 mm with the use of optional shims.

Each bracket can support up to 250kg, and is designed for stone up to 50mm thickness.

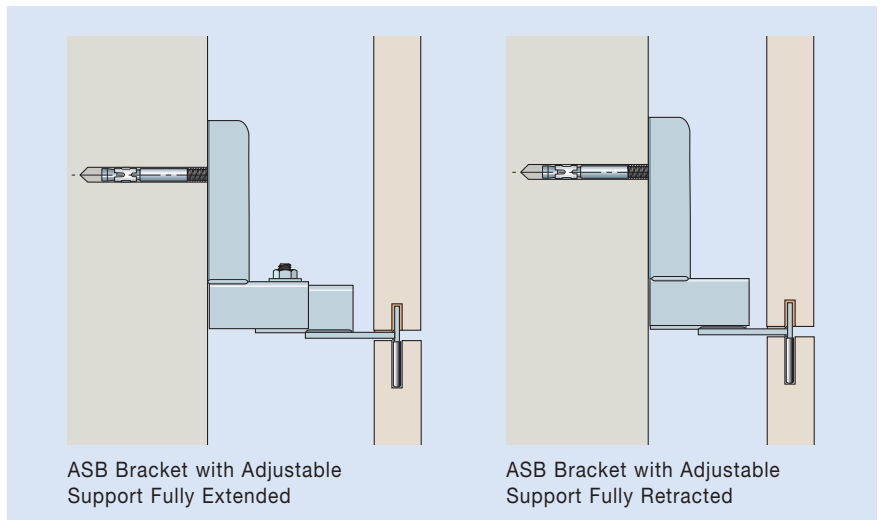

ASB Bracket with Adjustable Support Fully Extended

ASB Bracket with Adjustable Support Fully Retracted

Ancon Soffit Fixing

Ancon Soffit fixings are a simple and secure method of fixing thin facing slabs. This heavy duty support and restraint fixing comprises a stainless steel head and bolt and is quick and easy to install. The disc fixing is fully adjustable and able to support a safe working load of 600N in tension.

The stone should be checked to ensure it is capable of withstanding the localised bearing stress under the disc.

Ref.	Torque	Length	Disc size	Hole size
SF150	8 - 10Nm	150mm	50 x 5mm	8 x 65mm

Note: Other sizes can be manufactured on request.



Soffit Fixings

Masonry Support, Windposts & Lintels

Lintels

Leviat manufactures a complete range of galvanised and stainless steel lintels.

The Housing and Unilintel ranges are designed to suit the loading conditions found in the majority of residential and commercial buildings. Our comprehensive standard range consists of:

- Housing Lintels
- Unilintels
- Channel Lintels
- Solid Wall Lintels
- Single Leaf Lintels

Bespoke lintels can also be manufactured to suit heavy duty situations, special shapes and wall constructions not covered by our standard range.

Corrosion Resistance

Ancon Lintels are manufactured from galvanised or Austenitic stainless steel.

Thermal Performance

The thermal transmittance, i.e. 'U' value, of any wall construction depends on the thermal characteristics of the individual components being used. The design of both the Housing Lintel and Unilintel is such that it allows for continuity of construction down to window head level.

Housing Lintels can be supplied insulated with CFC-free, high density polystyrene manufactured in accordance with BS 3837 : Part 1 : 2004 to be CFC-free with an ozone depletion potential of zero.

Structural Performance

The safe working loads are derived by calculation and supported by tests to establish their validity.

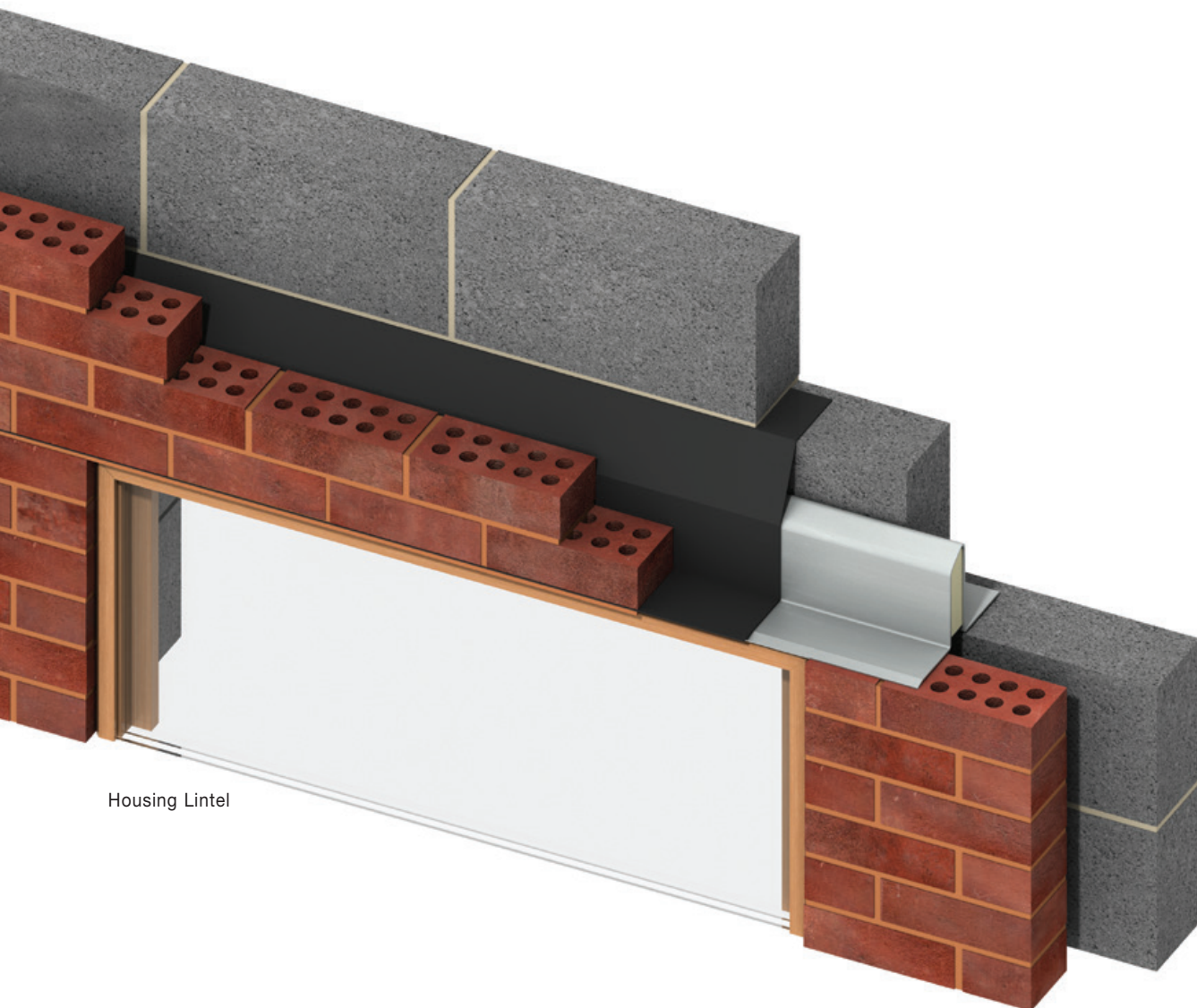

Housing Lintel

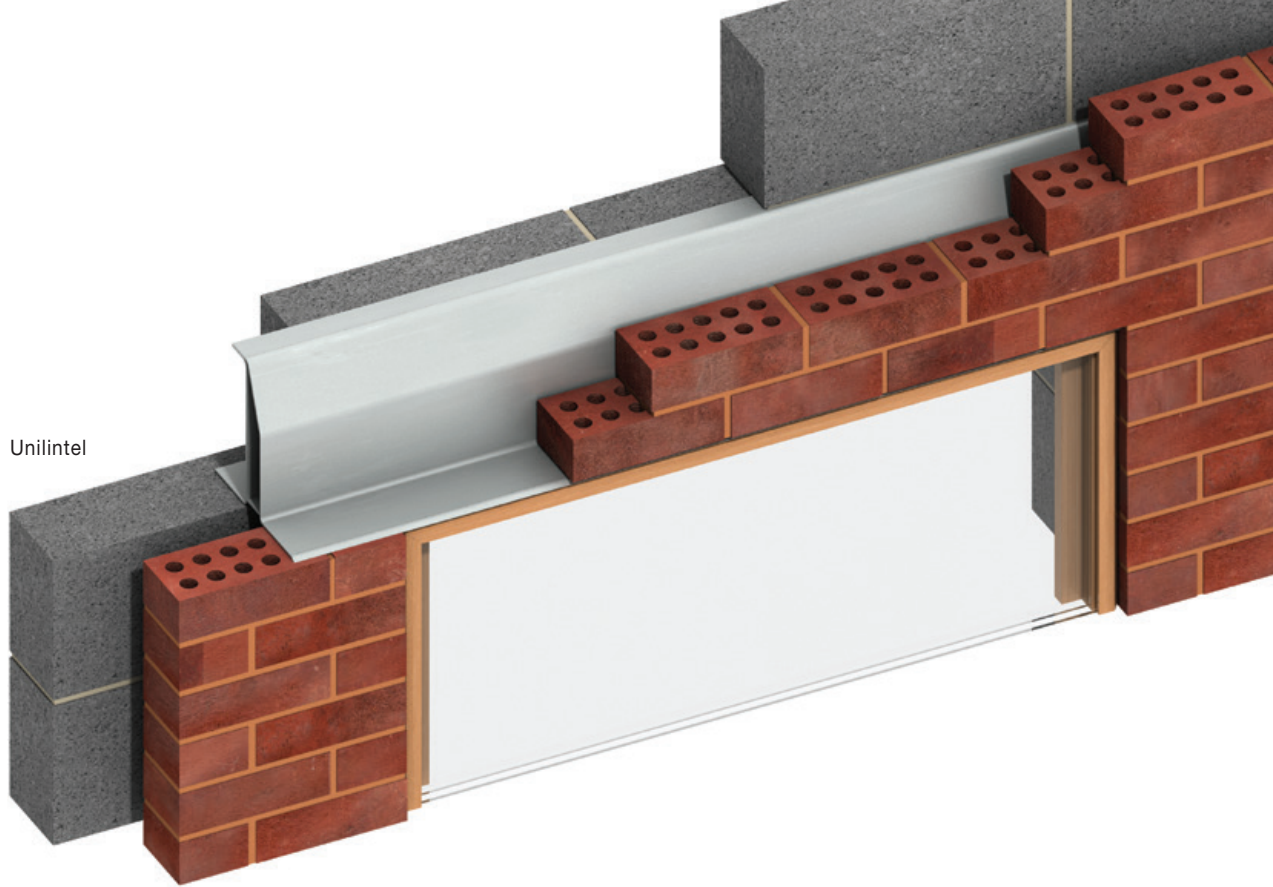

Unilintel

Load Ratios

The safe working loads for Housing Lintels and Unilintels in the tables on page 24 are for situations where the total distributed load on the lintel is shared between the inner and outer leaves in ratios of between 1:1 and 3:1 respectively. For other load ratios, point loads or lintels carrying concrete floors, please contact our Technical Services Team.

Installation

The lintel should be firmly bedded in mortar with at least 150mm end bearing onto a full brick/block. Please consult us when using limited bearing. The front and back of the lintel must be level before proceeding and a separate dpc incorporated if required.

When installing Housing Lintels and Unilintels the inner and outer leaves should be raised together to avoid twisting the lintel; blocks should continue for the full length of the inner flange. Masonry should have a maximum overhang of 30mm and blockwork should be built as close as possible to the upstand. Point loads should be applied at least 150mm above lintel flanges.

Although the lintels have a drip edge on the external flange to shed moisture, good practice should be followed at the junction of the window head and lintel by sealing with a suitable mastic, thereby ensuring that driving rain does not penetrate.

Weep vents are generally required above lintels at a maximum of 480mm centres. Each opening should have at least two weep holes and stop ends are required to prevent moisture penetration.

Long spanning lintels and all single leaf lintels will require propping during installation to limit deflections.

Technical Assistance

Our Technical Services Team is available to advise on specification, design, installation and structural loading conditions.

Masonry Support, Windposts & Lintels

Housing Lintels

These are suitable for most domestic, small commercial developments and framed structures. They are supplied complete with insulation and metal lathing to provide a plaster key. Housing lintels require a separate dpc.

When installing Housing Lintels and Unilintels the inner and outer leaves should be raised together to avoid twisting the lintel; blocks should continue for the full length of the inner flange. Masonry should have a maximum overhang of 25mm and blockwork should be built as close as possible to the upstand. Point loads should be applied at least 150mm above lintel flanges.

Cavity (mm)	Inner Leaf (mm)	Wall Widths (mm)	Ref.	Nom. Height (mm)	Gauge (mm)	Ixx (cm ⁴)	Zxx (cm ³)	Length (mm)	SWL (kN)
50-74	100-124	250-285	SH221	150	2.0	306.9	29.9	750-2100	20
			SH321	150	3.0	460.4	44.8	750-1650 1800-2550 2700-3000	33 24 20
			SH331	200	3.0	1300.0	89.4	750-2550 2700-3300 3450-3900	50 35 30
			SH221E	150	2.5	402.0	38.0	750-2550	20
			SH321E	150	3.0	482.4	45.6	750-1650 1800-2550 2700-3000	30 20 18
			SH331E	200	3.0	1345.0	90.8	750-2550 2700-3300 3450-3900	40 30 25

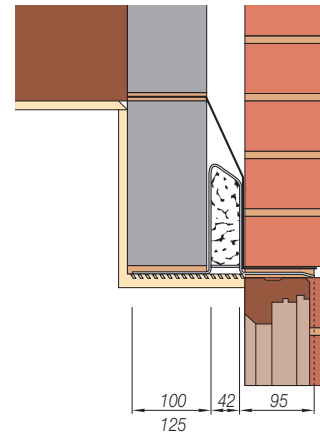

50-74mm Cavity

Unilintels

Unilintels are designed for the heavy duty loading conditions often found in commercial developments and have the top flange built into the inner leaf. They are complete with metal lathing to provide a plaster key. Insulation can be supplied as an optional extra.

Cavity (mm)	Inner Leaf (mm)	Wall Widths (mm)	Ref.	Nom. Height (mm)	Gauge (mm)	Ixx (cm ⁴)	Zxx (cm ³)	Length (mm)	SWL (kN)
50-74	100-124	250-285	SU221	157	2.5/2.0	535.8	57.5	750-2100 2250-2700	30 25
			SU321	157	3.0/2.0	590.5	63.5	750-2100 2250-2700	38 31
			SU231	200	2.5/2.0	1317.4	99.6	750-2100 2250-2700	50 48
			SU331	200	3.0/2.0	1462.0	110.7	2550-3150 3300-3900	48 36
			SU431	200	4.0/4.0	2391.6	180.4	3000-3900	58
			SU531	200	5.0/5.0	2989.4	225.6	3000-3900	65
50-74	125-150	275-310	SU221E	157	2.5/2.0	562.7	58.8	750-2100 2250-2700	30 25
			SU321E	157	3.0/2.0	622.7	65.0	750-2100 2250-2700	38 31
			SU231E	200	2.5/2.0	1380.7	101.9	750-2100 2250-2700	50 48
			SU331E	200	3.0/2.0	1527.7	112.8	2550-3150 3300-3900	48 36
			SU431E	200	4.0/4.0	2505.6	186.0	3000-3900	58
			SU531E	200	5.0/5.0	3132.0	232.5	3000-3900	65

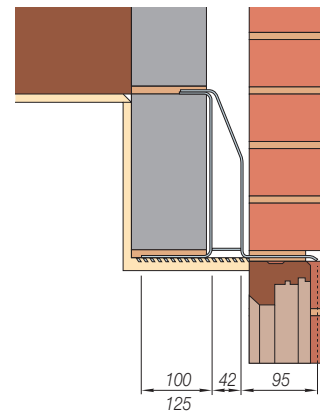

50-74mm Cavity

Single Leaf Lintels/Angle Lintels

These lintels carry a single leaf, usually the external leaf, of a cavity wall. The lintel can be supplied with lips to either leg if required. Single leaf lintels require propping during installation to limit deflections. A separate dpc is required.

Outer Leaf (mm)	Ref.	Height (mm)	Gauge (mm)	Ixx (cm ⁴)	Zxx (cm ³)	Length (mm)	SWL (kN)
95-120	SL31	95	3	50.7	7.2	750-1800	4
	SL41	95	4	66.5	9.5	750-2400	6
	SL32	150	3	175.4	17.1	750-2400	8
	SL42	150	4	231.2	22.6	750-2400 2550-3300	12 10
	SL33	200	3	379.7	29.1	750-2400 2550-3300	15 12
	SL43	200	4	502.5	38.6	750-2400 2550-3300	20 14
	SL53	200	5	622.3	48.0	750-1800 1950-3300	30 26

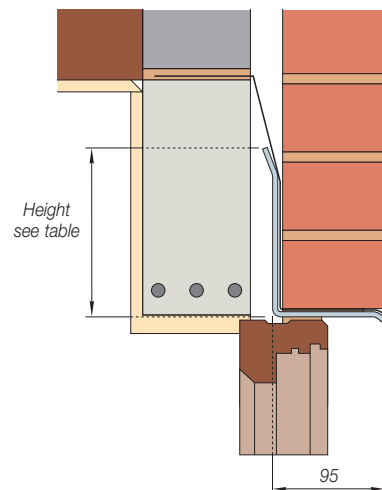

Single Leaf Lintel

Channel Lintels

The Channel Lintel can be supplied with welded metal lathing on any side to provide a plaster key. For wall widths over 100mm, please contact us.

Width 100mm

Ref.	Nom. Height (mm)	Gauge (mm)	Ixx (cm ⁴)	Zxx (cm ³)	Length (mm)	SWL (kN)
SC322	170	3.0	328.4	37.3	750-1500	20
SC422	170	4.0	437.8	49.7	1650-2100	20
SC522	170	5.0	547.3	62.2	2250-3000	20
SC332	255	3.0	837.7	65.4	750-1500	20
SC432	255	4.0	1117.0	87.2	1650-2100	30
SC532	255	5.0	1396.2	109.1	2250-3000	40

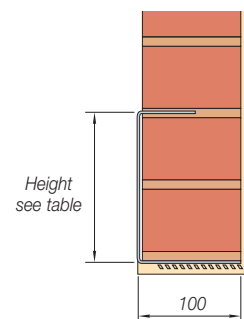

Channel Lintel

Note: Channel Lintels

These lintels have been tested using composite action with surrounding masonry to BS 5628, and should be suitably restrained during construction.

Solid Wall Lintels

For use with solid walls, the Standard Duty has a top flange built into the brickwork. The Light Duty version is suitable for spans up to 2700mm.

Width 200mm (Light Duty)

Ref.	Nom. Height (mm)	Gauge (mm)	Ixx (cm ⁴)	Zxx (cm ³)	Length (mm)	SWL (kN)
SS312	75	3.0	57.3	9.7	750	12
					900-1500	10
SS422	150	4.0	371.3	35.4	1650	15
					1800-1950	14
					2100-2700	13

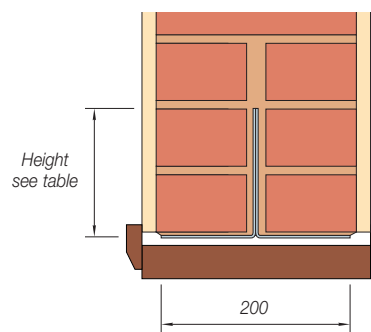

Light Duty Solid Wall Lintel

Width 200mm (Standard Duty)

Ref.	Nom. Height (mm)	Gauge (mm)	Ixx (cm ⁴)	Zxx (cm ³)	Length (mm)	SWL (kN)
SS321	170	3.0	503.6	58.7	750-1800	40
					1950-2700	30
SS331	255	3.0	1581.2	125.9	750-1800	60
					1950-2700	50
					2850-3600	40
SS431	255	4.0	2108.3	167.8	750-3900	55

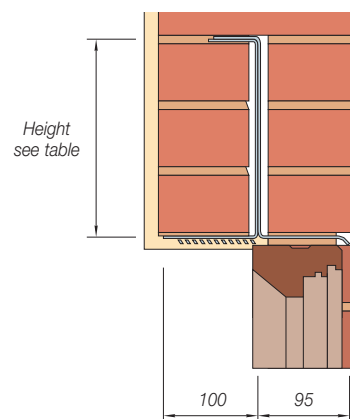

Standard Duty Solid Wall Lintel

Masonry Support, Windposts & Lintels

Custom Lintels

In order to meet the requirements of today's challenging industry, we can design and manufacture special lintels for applications where standard lintels are unsuitable.

Solutions can be supplied for complex features such as corbels and other architectural details.

Special cranked, bay, corner and cantilevered corners are available in addition to the following arch shapes:

- Segmental arch
- Semi-circular arch
- Apex arch
- Gothic arch
- Flat top arch
- Double arch
- Arched on plan

Our Technical Services Team will offer advice on the most appropriate lintel or alternative method of supporting masonry.

The following information will aid the design of a custom lintel and if available should be supplied with your enquiry.

- Wall construction: outer leaf, inner leaf and cavity size.
- Clear span of opening.
- Bearings available (if less than 225mm).
- Radius or rise of arch and angles for apex/ cranked and corner lintels.

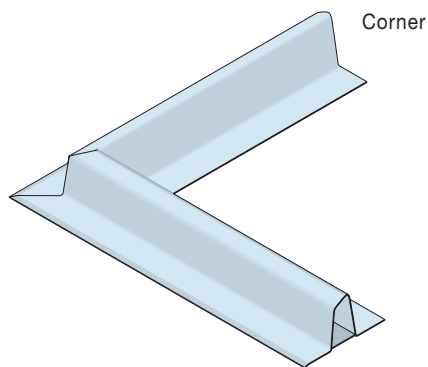
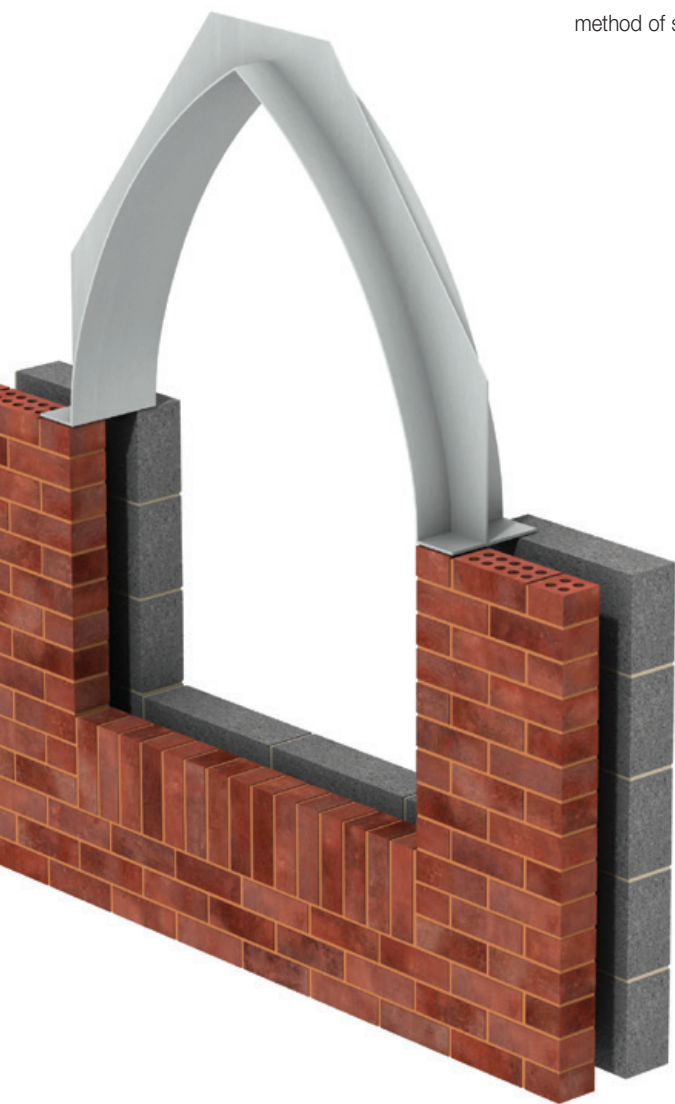

Corner

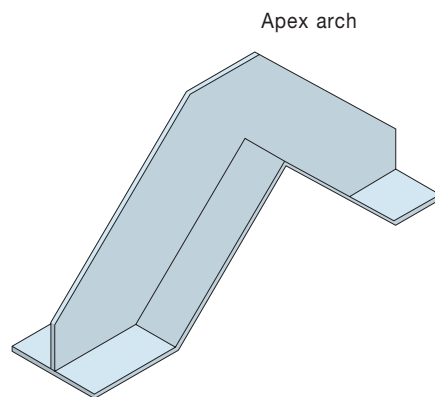

Apex arch

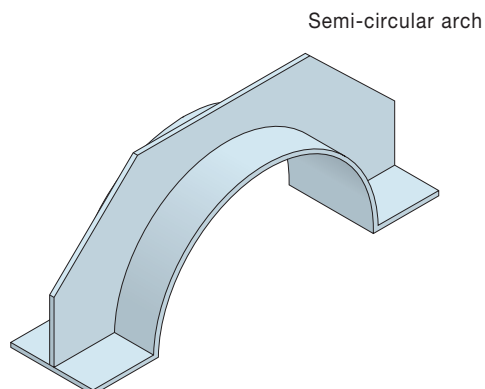

Semi-circular arch

Windposts

Design Considerations

Large panels of masonry or panels with openings can often be difficult to justify structurally. The traditional solutions have been to either increase the thickness of the wall or introduce an additional column. Ancon Windposts fit within the wall allowing the existing thickness to be maintained.

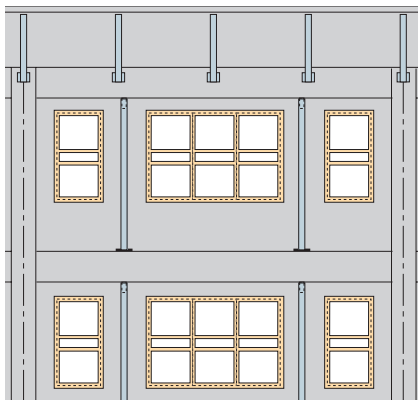

Typical Layout of Windposts and Parapet Posts on an Elevation of Brickwork



WP2 Fixed to Concrete Structure

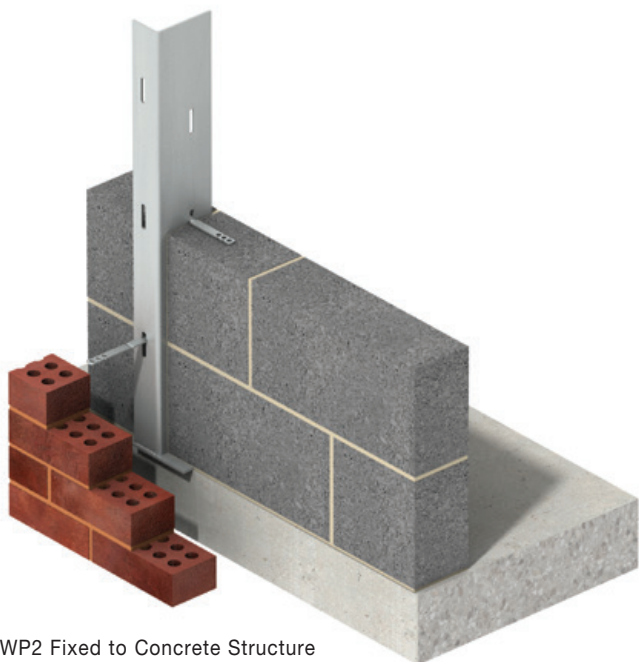

Ancon WP2 Windposts

The Ancon WP2 is an angle section windpost. One leg of the angle is built into the blockwork, and the blockwork tied through the leg of the windpost to minimise any possible movement or cracking of internal finishes. If a vertical movement joint is required in place of a tied joint, ties with a plain end on one side can be supplied.

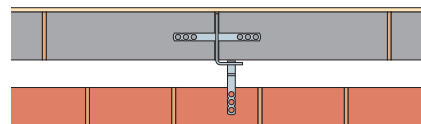

WP2 Windpost with SDN and SNS Ties in Cavity Wall

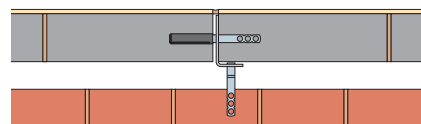

WP2 Windpost at Vertical Movement Joint in the Inner Leaf of Blockwork with PNS Ties Across the Post

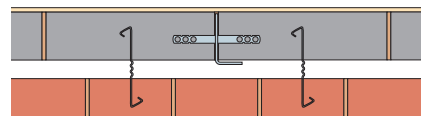

WP2 Windpost with SNS Tie and AMD Wall Ties Each Side of the Post

Ancon WP4 Windposts

Ancon WP4 Windposts are generally used in internal blockwork walls that have a 'fair faced' finish to both sides and where the windposts cannot protrude beyond either face. Sometimes referred to as 'spine' posts they are flat plates designed to fit within the wall. Although the depth of a WP4 post is limited by the width of the masonry (ideally 20mm less than the wall width) the thickness of the post can vary to increase its load capacity. Blockwork is tied through the post. Debonded ties can be used if the post is positioned at a movement joint.



WP4 Windpost with SNS Tie in Single Skin Blockwork

Masonry Support, Windposts & Lintels

Windpost Design

Ancon Windposts are designed to span vertically between floors to provide lateral support for panels of brickwork. The windposts will usually be restrained by the brickwork and designed as 'simply supported beams'.

Deflection under wind load will often limit the maximum loading. Windposts can be designed as 'propped cantilevers' to limit deflection, this however will require a much larger base connection which in many cases may be difficult to accommodate.

Connections to the frame are designed to permit adjustment during installation. Serrated surfaces will be provided where adjustment is in the direction of the load. The top connection allows for shrinkage or vertical movement of the frame to take place. The type of fixing will depend on the nature of the frame. Expansion bolts are normally supplied for concrete frames and set screws will be supplied for steel frames. The table on page 31 includes part of the range of Ancon windposts. For further information or advice on specific applications, please contact our Technical Services Team.

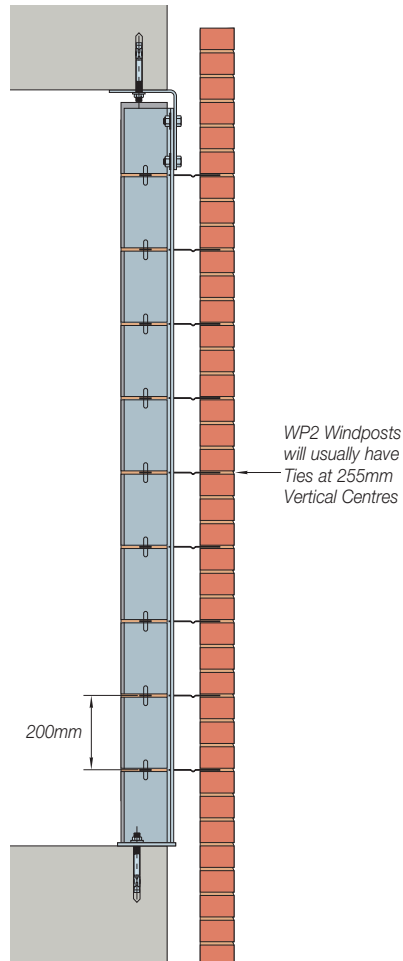

WP2 Windpost Fixed to Top and Soffit of Concrete

Details for Specification and Ordering

The following clause can be adapted for your bill of quantities to aid the specification of Ancon Windposts and Parapet Posts.

Ancon Windposts WP2 130 x 70 x 6 in grade 304 stainless steel, overall length 2750mm complete with all ties and end connections. Fixed with Ancon FBN12/15 A4-115 Expansion Bolts.

Ancon Windposts are designed and manufactured to suit each individual project. Sufficient time should be allowed for the design, approval and manufacturing process when placing orders for windposts.

Parapet and Spandrel Posts

Ancon Parapet and Spandrel Posts are restrained by the brickwork and designed as 'cantilevers'. The base connection will need to be sufficient to resist the 'bending moment' and may in some cases be difficult to accommodate within the floor construction. The height of these posts is unlikely to be more than 1.6 metres. The table on page 31 includes part of the range of Ancon parapet and spandrel posts. For further information or advice on specific applications, please contact our Technical Services Team.

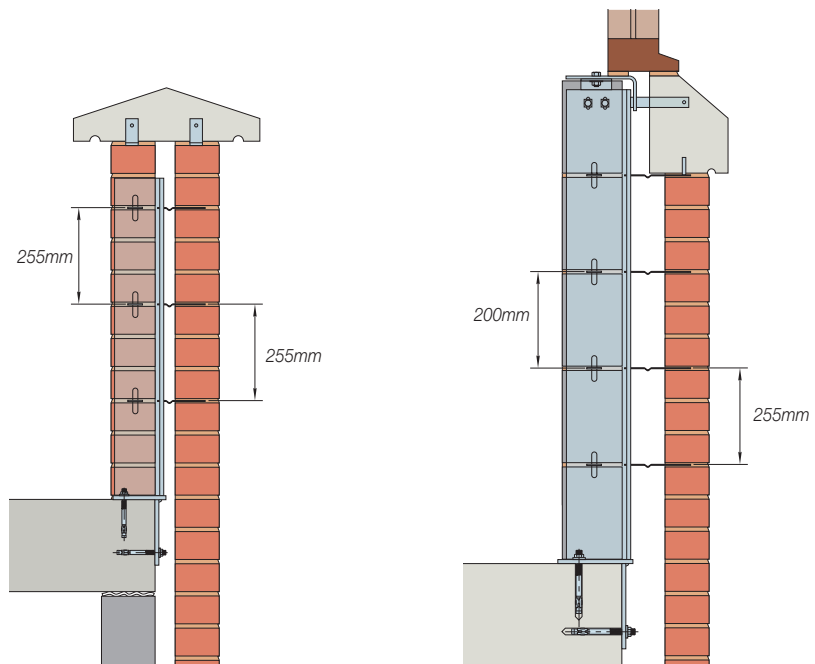

WP2 Parapet Post Fixed to Top and Face of Concrete

WP2 Spandrel Post Fixed to Top and Face of Concrete, with Horizontal Rail at the Top of the Post

Fixings for Windposts and Parapet Posts

Connections to the frame can be made in a variety of ways and will depend on the type of post, structure and fixing being used. Typical examples of connections are shown. For more specific details please consult our Technical Services Team.



Top Connection of a WP2 Windpost to the Soffit of the Concrete



Top Connection of a WP2 Windpost to the Underside of a Steel Beam



Top Connection of a WP2 Windpost to the Underside of a Timber Wall Plate



Base Connection of a WP2 Windpost to the Top of a Concrete Slab



Base Connection of a WP2 Parapet Post to the Top and Face of a Concrete Slab

Top Connection of a WP2 Windpost to the Top of a Timber Wall Plate



Masonry Support, Windposts & Lintels

Wall Ties

A range of ties is available to suit Ancon Windposts. SDN Ties are used to the outer leaf and SPN Ties to the inner leaf. SNS Ties are used across the posts in the inner blockwork and can be supplied with a debonding sleeve for use where there is a vertical movement joint.

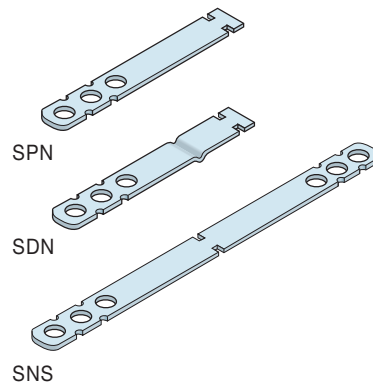

WP2 Windpost Bolted to the Top of a Concrete Floor Slab

Connections

The choice of fixing and its position is dependant on the type and length of the windpost and the structure to which it is being fixed. We design fixing details for the top and base of each windpost and a drawing is issued for approval prior to manufacture.

The bolt in the slotted connection at the top of the windpost is positioned so that vertical movement of the frame can take place.

The details shown are typical. Please contact our Technical Services Team for more information.

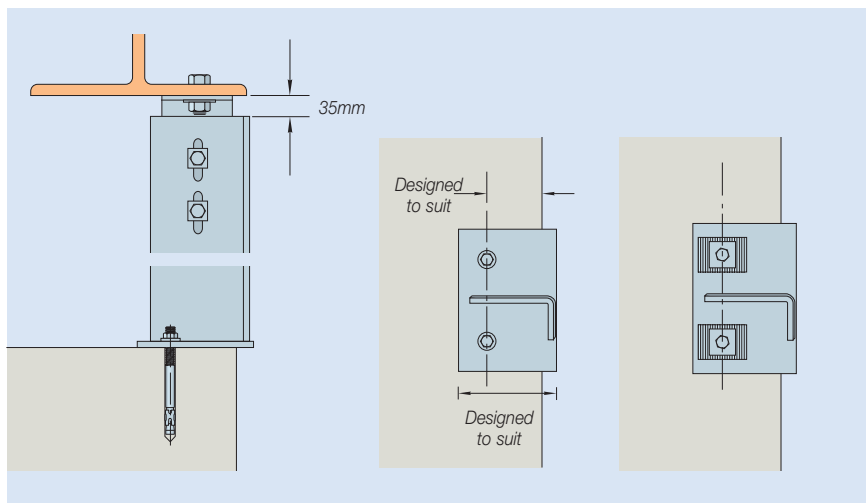

WP2 Windpost Bolted to a Steel Beam at the Top and Fixed to Concrete at the Base

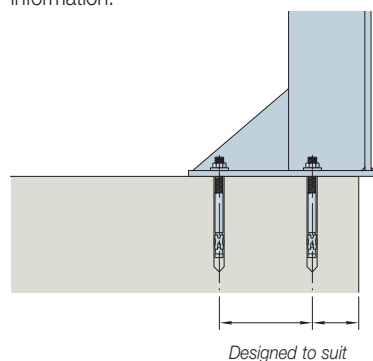

WP2 Parapet Post Fixed using Expansion Bolts into the Concrete

Properties and Performance Loads for Windposts

Ancon Windposts are designed as 'simply supported beams' with a maximum stress of 181MPa and a maximum deflection of span/360.

Ancon Parapet and Spandrel Posts are designed with a maximum stress of 181MPa and a maximum deflection of height/180.

The tables below include examples only. Please contact us for other applications.

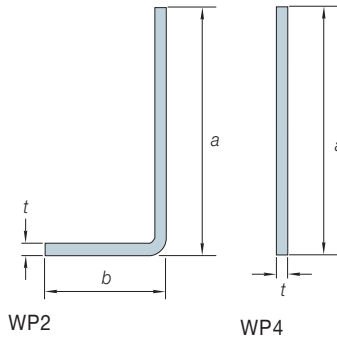

Properties and Performance of WP2 Windposts

	Size a x b x t	Ixx cm ⁴	Zxx cm ³	TOTAL Unfactored SWL (kN) per Post (uniformly distributed)							
				2.5m	3.0m	3.5m	4.0m	4.5m	5.0m	5.5m	6.0m
WP2	125 x 70 x 4	125.9	15.2	8.6	6.0	4.4	3.4	2.7	2.1	1.8	1.5
	140 x 70 x 4	171.1	18.8	10.9	8.1	6.0	4.6	3.6	2.9	2.4	2.0
	130 x 70 x 6	202.1	24.0	13.8	9.6	7.0	5.4	4.3	3.4	2.9	2.4
	155 x 70 x 4	225.3	22.7	13.2	10.7	7.8	6.0	4.7	3.8	3.2	2.7
	170 x 70 x 4	289.2	27.0	15.6	13.0	10.1	7.7	6.1	4.9	4.1	3.4
	150 x 70 x 6	298.5	31.4	16.7	14.1	10.4	8.0	6.3	5.1	4.2	3.5
	160 x 70 x 6	355.8	35.4	16.7	16.9	12.4	9.5	7.5	6.1	5.0	4.2
	185 x 70 x 4	363.5	31.5	16.7	15.2	12.7	9.7	7.7	6.2	5.1	4.3
	150 x 80 x 8	406.6	42.2	16.7	19.3	14.2	10.8	8.6	6.9	5.7	4.8
	185 x 70 x 5	448.8	39.1	16.7	18.9	15.6	12.0	9.5	7.7	6.3	5.3
	160 x 80 x 8	485.1	47.7	16.7	20.0	16.9	12.9	10.2	8.3	6.8	5.7
	200 x 70 x 5	554.5	45.2	16.7	20.0	18.7	14.8	11.7	9.5	7.8	6.6

Note: Figures in bold indicate that these posts require ties to the outer leaf at 255mm centres. Ties to the inner leaf will always be at 200mm centres.

Properties and Performance of WP2 Parapet Posts

	Size a x b x t	Ixx cm ⁴	Zxx cm ³	0.8m	TOTAL Unfactored SWL (kN) per Post (uniformly distributed)					2.0m
					1.0m	1.2m	1.4m	1.6m	1.8m	
WP2	140 x 70 x 3	130.5	14.3	5.3	5.2	4.3	3.7	3.2	2.8	2.5
	125 x 70 x 4	125.9	15.2	5.3	5.5	4.6	4.0	3.5	3.1	2.8
	140 x 70 x 4	171.1	18.8	5.3	6.7	5.7	4.9	4.3	3.8	3.4
	130 x 70 x 6	202.1	24.0	5.3	6.7	7.3	6.2	5.5	4.8	4.4
	155 x 70 x 4	225.3	22.7	5.3	6.7	6.9	5.9	5.2	4.6	4.1
	170 x 70 x 4	289.2	27.0	5.3	6.7	8.0	7.0	6.1	5.4	4.9
	150 x 70 x 6	298.5	31.4	5.3	6.7	8.0	8.1	7.1	6.3	5.7
	160 x 70 x 6	355.8	35.4	5.3	6.7	8.0	9.2	8.0	7.1	6.4
	185 x 70 x 4	363.5	31.5	5.3	6.7	8.0	8.2	7.2	6.4	5.7
	150 x 80 x 8	406.6	42.2	5.3	6.7	8.0	9.3	9.6	8.5	7.7
	185 x 70 x 5	448.8	39.1	5.3	6.7	8.0	9.3	8.9	7.9	7.1
	160 x 80 x 8	485.1	47.7	5.3	6.7	8.0	9.3	10.8	9.6	8.6
200 x 70 x 5	554.5	45.2	5.3	6.7	8.0	9.3	10.2	9.1	8.2	

Note: Figures in bold indicate that these posts require ties to the outer leaf at 255mm centres. Ties to the inner leaf will always be at 200mm centres.

Properties and Performance of WP2 Parapet Posts

	Size a x b x t	Ixx cm ⁴	Zxx cm ³	0.8m	Maximum Unfactored Point SWL at Top of Parapet Post (kN)					2.0m
					1.0m	1.2m	1.4m	1.6m	1.8m	
WP2	140 x 70 x 3	130.5	14.3	2.6	2.1	1.7	1.5	1.3	1.1	1.0
	125 x 70 x 4	125.9	15.2	2.8	2.2	1.8	1.6	1.4	1.2	1.1
	140 x 70 x 4	171.1	18.8	3.4	2.7	2.3	2.0	1.7	1.5	1.4
	130 x 70 x 6	202.1	24.0	4.4	3.5	2.9	2.5	2.2	1.9	1.7
	155 x 70 x 4	225.3	22.7	4.1	3.3	2.8	2.4	2.1	1.8	1.7
	170 x 70 x 4	289.2	27.0	4.9	3.9	3.3	2.8	2.4	2.2	2.0
	150 x 70 x 6	298.5	31.4	5.7	4.6	3.8	3.3	2.9	2.5	2.3
	160 x 70 x 6	355.8	35.4	6.4	5.1	4.3	3.7	3.2	2.9	2.6
	185 x 70 x 4	363.5	31.5	5.7	4.6	3.8	3.3	2.9	2.5	2.3
	150 x 80 x 8	406.6	42.2	7.7	6.1	5.1	4.4	3.8	3.4	3.1
	185 x 70 x 5	448.8	39.1	7.1	5.7	4.7	4.1	3.6	3.2	2.8
	160 x 80 x 8	485.1	47.7	8.6	6.9	5.8	4.9	4.3	3.8	3.5
200 x 70 x 5	554.5	45.2	8.2	6.6	5.5	4.7	4.1	3.6	3.3	

Properties and Performance of WP4 Windposts

	Size a x t	Ixx cm ⁴	Zxx cm ³	TOTAL Unfactored SWL (kN) per Post (uniformly distributed)							
				2.5m	3.0m	3.5m	4.0m	4.5m	5.0m	5.5m	6.0m
WP4	90 x 8	48.6	10.8	3.3	2.3	1.7	-	-	-	-	-
	100 x 8	66.6	13.3	4.6	3.2	2.3	1.8	1.4	-	-	-
	110 x 8	88.7	16.1	6.1	4.2	3.1	2.4	1.9	1.5	-	-
	120 x 8	115.2	19.2	7.9	5.5	4.0	3.1	2.4	2.0	1.6	1.4

Masonry Support, Windposts & Lintels

Channel And Bolt Fixings

This is a selection of Ancon fixings. For complete information please refer to the Ancon Channel and Bolt Fixings brochure.

Cast-in Channels and T-Head Bolts

Cast-in Channels provide the necessary adjustment required when fixing to concrete and can eliminate site drilling. Fixing to channels is by 'T' head bolts. These are inserted into the channel and turned through 90°. The bolt must then be tightened to the correct torque.



Expansion Bolts

The Single Expansion bolt is a cost-effective anchor, available in grade 1.4362 (duplex) stainless steel in a wide range of sizes. We also supply high performance through bolts which have double expansion clips that reduce axial and edge spacing and achieve high performance even in cracked concrete.



Resin Anchors

The cartridge contains vinylester resin, quartz granules and a hardener, and provides an expansion-free anchorage for stainless steel studs. These can be used in a variety of solid or hollow materials including concrete and stone.



Ancon Steelgrip

Ancon Steelgrip is a high performance fixing which simplifies the fixing of masonry support systems to hollow steel sections where access is only available from one side. This bolt is only available for use with Ancon systems. It features a serrated washer that corresponds with the serrations on all Ancon brackets. As the head is tightened to the correct torque, the sleeve expands.



Set Screws for Steel Frames

Ancon stainless steel set screws, nuts and washers are available in a range of thread sizes (M6 to M20) and are manufactured from grades A2 (1.4301) and A4 (1.4401) stainless steel. Set screws can be shrink-wrapped and are supplied complete with nylon washers to prevent bi-metallic corrosion when fixing to steel.



Projects



AM60 Building, Brisbane



Orange Hospital, New South Wales



Woolworths Corporation Centre, New South Wales



Trinity Apartments, New South Wales

Wall Ties and Restraint Fixings

In addition to standard cavity and veneer wall ties, Leviat manufactures ties in a variety of lengths and types for restraining brickwork, blockwork and stonework. These ties can be fixed to concrete and structural steelwork, as well as any type of masonry.

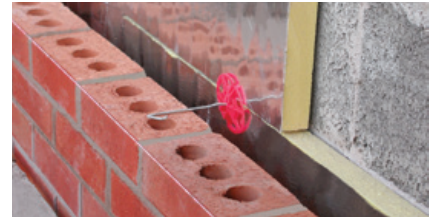

Tension Systems

Tie bars are increasingly being used in structures and buildings as an architectural as well as a structural element. Ancon Tension Systems comprise a range of components which can be supplied in carbon steel or stainless steel in a variety of sizes and finishes. A variety of assemblies can be created from simple tie bars to complex bracing systems involving several bars joined at one point.



© Darcy Schnack-JAM Photographics Ltd

Shear Load Connectors

Ancon DSD and ESD Shear Load Connectors are used to transfer shear across expansion and contraction joints in concrete. They are more effective at transferring load and allowing movement to take place than standard dowels, and can be used to eliminate double columns at structural movement joints in buildings. The Q version features a rectangular box section to allow lateral movement in addition to longitudinal movement. A 'Lockable' dowel is also available for temporary movement joints in post-tensioned concrete frames.



Design Program Available

Reinforcing Bar Couplers

The use of reinforcing bar couplers can provide significant advantages over lapped joints. Design and construction of the concrete can be simplified and the amount of reinforcement reduced. The range includes parallel threaded and mechanically bolted couplers.



Punching Shear Reinforcement

Ancon Shearfix is used within a slab to provide additional reinforcement from punching shear around columns. The system consists of double-headed steel studs welded to flat rails and is designed to suit the load conditions and slab depth at each column using our free calculation software.



Design Program Available

Worldwide contacts for Leviat:

Australia

Leviat
98 Kurrajong Avenue,
Mount Druitt Sydney, NSW 2770
Tel: +61 - 2 8808 3100
Email: info.au@leviat.com

Austria

Leviat
Leonard-Bernstein-Str. 10
Saturn Tower, 1220 Wien
Tel: +43 - 1 - 259 6770
Email: info.at@leviat.com

Belgium

Leviat
Industrielaan 2
1740 Ternat
Tel: +32 - 2 - 582 29 45
Email: info.be@leviat.com

China

Leviat
Room 601 Tower D, Vantone Centre
No. A6 Chao Yang Men Wai Street
Chaoyang District
Beijing · P.R. China 100020
Tel: +86 - 10 5907 3200
Email: info.cn@leviat.com

Czech Republic

Leviat
Business Center Šafránková
Šafránková 1238/1
155 00 Praha 5
Tel: +420 - 311 - 690 060
Email: info.cz@leviat.com

Finland

Leviat
Vädursgatan 5
412 50 Göteborg / Sweden
Tel: +358 (0)10 6338781
Email: info.fi@leviat.com

France

Leviat
6, Rue de Cabanis
FR 31240 L'Union
Toulouse
Tel: +33 - 5 - 34 25 54 82
Email: info.fr@leviat.com

Germany

Leviat
Liebigstrasse 14
40764 Langenfeld
Tel: +49 - 2173 - 970 - 0
Email: info.de@leviat.com

India

Leviat
309, 3rd Floor, Orion Business Park
Ghodbunder Road, Kapurbawdi,
Thane West, Thane,
Maharashtra 400607
Tel: +91 - 22 2589 2032
Email: info.in@leviat.com

Italy

Leviat
Via F.lli Bronzetti 28
24124 Bergamo
Tel: +39 - 035 - 0760711
Email: info.it@leviat.com

Malaysia

Leviat
28 Jalan Anggerik Mokara 31/59
Kota Kemuning, 40460 Shah Alam
Selangor
Tel: +603 - 5122 4182
Email: info.my@leviat.com

Netherlands

Leviat
Oostermaat 3
7623 CS Borne
Tel: +31 - 74 - 267 14 49
Email: info.nl@leviat.com

New Zealand

Leviat
2/19 Nuttall Drive, Hillsborough,
Christchurch 8022
Tel: +64 - 3 376 5205
Email: info.nz@leviat.com

Norway

Leviat
Vestre Svanholmen 5
4313 Sandnes
Tel: +47 - 51 82 34 00
Email: info.no@leviat.com

Philippines

Leviat
2933 Regus, Joy Nostalg,
ADB Avenue
Ortigas Center
Pasig City
Tel: +63 - 2 7957 6381
Email: info.ph@leviat.com

Poland

Leviat
Ul. Obornicka 287
60-691 Poznan
Tel: +48 - 61 - 622 14 14
Email: info.pl@leviat.com

Singapore

Leviat
14 Benoi Crescent
Singapore 629977
Tel: +65 - 6266 6802
Email: info.sg@leviat.com

Spain

Leviat
Poligono Industrial Santa Ana
c/ Ignacio Zuloaga, 20
28522 Rivas-Vaciamadrid
Tel: +34 - 91 632 18 40
Email: info.es@leviat.com

Sweden

Leviat
Vädursgatan 5
412 50 Göteborg
Tel: +46 - 31 - 98 58 00
Email: info.se@leviat.com

Switzerland

Leviat
Grenzstrasse 24
3250 Lyss
Tel: +41 - 31 750 3030
Email: info.ch@leviat.com

United Kingdom

Leviat
President Way, President Park,
Sheffield, S4 7UR
Tel: +44 - 114 275 5224
Email: info.uk@leviat.com

United States of America

Leviat
6467 S Falkenburg Rd.
Riverview, FL 33578
Tel: (800) 423-9140
Email: info.us@leviat.us

For countries not listed

Email: info@leviat.com

Leviat.com

Notes regarding this catalogue

© Protected by copyright. The construction applications and details provided in this publication are indicative only. In every case, project working details should be entrusted to appropriately qualified and experienced persons. Whilst every care has been exercised in the preparation of this publication to ensure that any advice, recommendations or information is accurate, no liability or responsibility of any kind is accepted by Leviat for inaccuracies or printing errors. Technical and design changes are reserved. With a policy of continuous product development, Leviat reserves the right to modify product design and specification at any time.

For more information on the following products, please contact:

**Masonry, Structural and
Precast Concrete products:**

+64 (0) 3 376 5205
info.ancon.nz@leviat.com
Ancon.co.nz

**Remedial Masonry
products:**

+64 (0) 3 376 5205
info.helifix.nz@leviat.com
Helifix.co.nz

General Enquiries

+64 (0) 3 376 5205
Leviat.com

Sales Offices and Production

North Island:

246D James Fletcher Drive
Otahuhu
Auckland 2024
New Zealand

South Island:

2/19 Nuttall Drive
Hillsborough
Christchurch 8022
New Zealand

Leviat.com

Leviat[®]
A CRH COMPANY

Imagine. Model. Make.

Leviat.com