

Leviat[®]
A CRH COMPANY

New Zealand Edition



Ancon[®]
Reinforcing Bar
Couplers and Anchors
for the Construction Industry

October 2021



We are one team. **We are Leviat.**

Leviat is the new name of CRH's construction accessories companies worldwide.

Under the Leviat brand, we are uniting the expertise, skills and resources of Ancon and its sister companies to create a world leader in fixing, connecting and anchoring technology.

The products you know and trust will remain an integral part of Leviat's comprehensive brand and product portfolio. As Leviat, we can offer you an extended range of specialist products and services, greater technical expertise, a larger and more agile supply chain and better, faster innovation.

By bringing together CRH's construction accessories family as one global organisation, we are better equipped to meet the needs of our customers, and the demands of construction projects, of any scale, anywhere in the world.

This is an exciting change. Join us on our journey.

Read more about Leviat at [Leviat.com](https://www.leviat.com)



Our product brands include:

Ancon[®]

Connolly

HALFEN

HELIFIX

ISEDIO

PLAKA



60

locations

sales in
30+
countries

3000

people worldwide

Imagine. Model. Make.

Leviat.com

Reinforcing Bar Couplers and Anchors

Simplify the design and construction of concrete

Lapped joints are not always an appropriate means of connecting reinforcing bars. The use of laps can be time consuming in terms of design and installation and can lead to greater congestion within the concrete because of the increased amount of rebar used. Anchorages erected through cogged or hooked bar ends can lead to similar problems.

Ancon couplers can simplify the design and construction of reinforced concrete and reduce the amount of reinforcement required.

Anchors create an anchorage in the concrete, replacing the need for cogged or hooked bar ends and on-site bar straightening.

Lapped joints are dependent upon the concrete for load transfer. For this reason any degradation in the integrity of the

concrete could significantly affect the performance of the joint.

The strength of a mechanical splice is independent of the concrete in which it is located and will retain its strength despite loss of cover resulting from impact damage or seismic event.

The range of Ancon reinforcing bar couplers and anchors is the most comprehensive available and includes parallel threaded and mechanically bolted couplers to suit all common bar diameters from 12mm to 40mm.



Contents

<u>Coupler and Anchor Selection</u>	<u>6-7</u>	<u>RT KSN Anchors</u>	<u>14</u>
<u>RT Threaded Couplers</u>	<u>8-9</u>	<u>MBT ET Series</u>	<u>15-16</u>
<u>RT Positional Couplers</u>	<u>10-11</u>	<u>MBT Transition Series</u>	<u>17-18</u>
<u>RT Weldable Couplers</u>	<u>12</u>	<u>MBT Headed Anchors</u>	<u>19</u>
<u>Dumbbell-Shaped Bars</u>	<u>13</u>	<u>Nut Runner</u>	<u>20</u>
<u>Coupled Cogged Bars</u>	<u>13</u>	<u>Other Ancon Products</u>	<u>20</u>
<u>RT Headed Anchors</u>	<u>14</u>		



Reinforcing Bar Couplers and Anchors

For many years the use of mechanical couplers to join reinforcing bars has been regarded as a means of reducing the use of long bars. Similarly, the use of anchors has been widely acknowledged as a means of limiting on-site bar straightening. Engineers and contractors are now recognising the true benefits of using these systems to accelerate the speed of construction, increase productivity and simplify design details.

Coupler and Anchor Selection

Ancon reinforcing bar couplers and anchors are used on building and civil engineering projects worldwide.

The range includes threaded and mechanically bolted systems, both of which require different fixing methods. This, together with the quantity to be fixed and the location, will determine which is the most appropriate coupler for a particular situation.



RT Threaded Couplers and Anchors (pages 8-14)

The RT system is among the smallest and the most cost-effective in our range, when used on large scale, high volume projects. The RT range requires a parallel thread to be rolled onto the end of the reinforcing bar to be coupled prior to placement and fitting of the coupler. RT threaded couplers and anchors are supplied in plain carbon steel as standard.

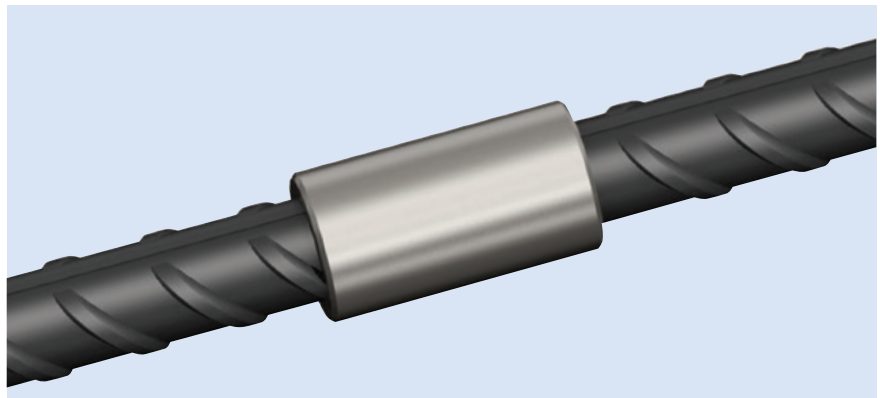

MBT Mechanically Bolted Couplers and Anchors (pages 15-19)

MBT couplers and anchors are suitable where it is not convenient to have the bar ends prepared for the RT system. The bars are supported within the coupler or anchor on two serrated saddles. Bars are locked in place by a series of special lockshear bolts, the heads of which shear off when the predetermined tightening torque is reached, providing a visual check of correct installation.

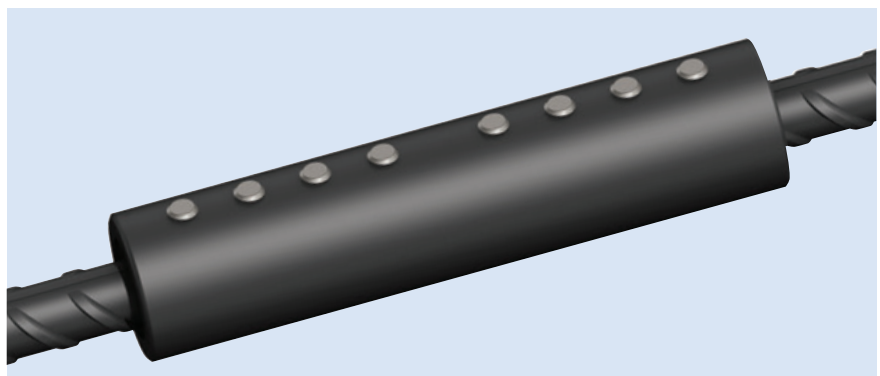

In New Zealand, couplers and anchors are available either direct from Leviat or through leading reinforcing bar suppliers. Threading of bar for use with Ancon threaded couplers is conducted in our factory.

Availability of Couplers

Bar Diameter (mm)	12	16	20	25	32	40
RT Standard Threaded Coupler	✓	✓	✓	✓	✓	✓
RT Positional Threaded Coupler	✓	✓	✓	✓	✓	✗
RT Weldable Threaded Coupler	✓	✓	✓	✓	✓	✗
RTHA Threaded Headed Anchor	✓	✓	✓	✓	✓	✓
RT KSN Anchor	✓	✓	✓	✗	✗	✗
MBT ET Bolted Coupler	✓	✓	✓	✓	✓	✓
MBT ET Bolted Transition Coupler	✓	✓	✓	✓	✓	✓
MBTHA Bolted Headed Anchor	✓	✓	✓	✓	✓	✓

Note: MBT bolted couplers for 50mm diameter bar are also available. Contact us for product details.

Coupler Range

Range	RT Threaded					MBT Bolted		
	Standard	Positional	Weldable	Headed Anchor	KSN Anchor	Coupler	Transition	Headed Anchor
Specification Code	RTC	RTPC	RTWC	RTHA	RT KSN	MBT	MBT	MBTHA
Bar Diameter (mm)	12-40	12-32	12-32	12-40	12-20	12-40	12-40	12-40
Bar End Preparation	Threaded	Threaded	Threaded	Threaded	Threaded	No	No	No
Assembly Tool	Wrench	Wrench	Wrench	Wrench	Wrench	Wrench or *Nut Runner		
Product Code	RTC12-40	RTPC12-32	RTWC12-32	RTHA12-40	RT KSN12-20 S/M/L	MBT12C – MBT40C	MBT20/12C - MBT40/32C	MBTHA12H - MBTHA40H

*Although larger 25-40mm sizes can be tightened using a hand ratchet wrench, we recommend the use of an electric or pneumatic wrench designed to deliver a steady tightening force to the bolts.

Coupler Specification

Ancon couplers and anchors can be specified using the suggested specification codes listed below. These codes are also included in the tabulated data in each section of this brochure.

Bar Diameter (mm)	12	16	20	25	32	40
Threaded Standard Coupler	RTC12	RTC16	RTC20	RTC25	RTC32	RTC40
Threaded Positional Coupler	RTPC12	RTPC16	RTPC20	RTPC25	RTPC32	-
Threaded Weldable Coupler	RTWC12	RTWC16	RTWC20	RTWC25	RTWC32	-
Threaded Headed Anchor	RTHA12	RTHA16	RTHA20	RTHA25	RTHA32	RTHA40
RT KSN Anchor	RT KSN 12S/M	RT KSN 16S/M/L	RT KSN 20S/M/L	-	-	-
MBT Mechanically Bolted Coupler	MBT12C	MBT16C	MBT20C	MBT25C	MBT32C	MBT40C
MBT Mechanically Bolted Headed Anchor	MBTHA12H	MBTHA16H	MBTHA20H	MBTHA25H	MBTHA32H	MBTHA40H

CAD drawings of Ancon couplers/anchors are available to download from www.ancon.co.nz

Typical Application Guide

The following table provides a guide when selecting the most appropriate coupler or anchor for specific applications. Recommendations are based upon typical usage. For further assistance with coupler suitability and specification, please contact us.

Application	Threaded Coupler / Anchor	Bolted Coupler / Anchor
Wall to slab connection	✓	✗
Column construction	✓	✓
Extension / repairs to existing structures	✗	✓
Pre-cast element to pre-cast element connection	✓	✓
Closing of access openings	✓	✓
Rebar cage pre-fabrication	✓	✓
Hook bars to pile connection	✗	✓
Fatigue applications	✓	✓
Bar end terminations	✓	✓

Notes: Leviat recommends that NZS3101 be followed in all instances and that reinforcement couplers and anchors should not be used in plastic hinge zones or near critical load paths. Instead, coupling and anchoring of steel reinforcement should be limited to regions located away from these areas.



Reinforcing Bar Couplers and Anchors

RT Threaded Couplers

Ancon RT threaded couplers are among the smallest in the Ancon range, best suited to large scale projects requiring a high volume of couplers. Their small size allows them to be used in places where a larger coupling system may not fit, such as at the end of clogged bars in thin panels.

Reinforcing Bar Processing

The Ancon RT coupler system requires the process of threading the ends of the bars that are to be joined. The end of each bar is cut square and pressed before a rolling sequence is engaged to thread the bar. A nominal allowance of 50mm per threaded bar end should be made to allow for bar processing.

Testing

The Ancon RT system has been tested extensively in New Zealand using local and imported grade E, micro-alloyed reinforcing bar. Testing indicates that the RT system can meet strength, slip and cyclic slip performance criteria stipulated in the Concrete Structures Standard (NZS3101:2006 A3) and the NZTA Bridge Manual. Testing also suggests that variations in steel reinforcement materials, combined with cold-work production processes, may result in reduced ductility and ultimate tensile strength (UTS) in the spliced region relative to the performance of the parent material. Contact us to request a copy of the full New Zealand test details.

Leviat recommends that NZS3101 be followed in all instances and that reinforcement couplers and anchors should not be used in plastic hinge zones or near critical load paths. Instead, coupling and anchoring of steel reinforcement should be limited to regions located away from these areas.

Reinforcement couplers might be used in areas where there is sufficient redundancy in the system. For example, couplers and anchors might be used appropriately at wall to floor junctions to join small (12mm or 16mm) diameter bars installed at regular and close intervals e.g. 150 - 300mm centres.

RT Standard Couplers

The Standard RT Threaded coupler is suitable for connecting two bars of the same diameter, where one bar can be rotated. The ends of the bar are threaded for half the length of the coupler. Contact us regarding situations where rotation of the continuation bar is difficult or impossible.

RT Standard Coupler Dimensions

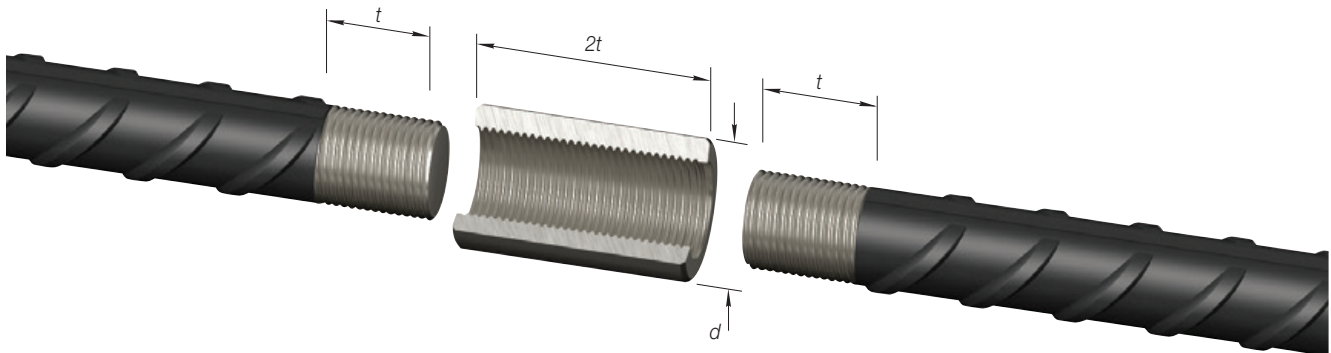

Bar Diameter (mm)		12	16	20	25	32	40
External Dia.	d	20	24	30	38	45	60
Coupler Length	$2t$	34	40	50	54	75	90
Thread Size		M13	M17	M21	M26	M33	M41
Thread Pitch		1.75	2.5	2.5	3.5	3.5	3.5
Weight (kg)		0.05	0.08	0.16	0.29	0.48	0.81
Specification / Product Code		RTC12	RTC16	RTC20	RTC25	RTC32	RTC40
Product Code - Thread		RTT12	RTT16	RTT20	RTT25	RTT32	RTT40

Note: All dimensions are approximate and subject to change without notice. Contact us for details regarding RT50 option. Threading of reinforcing bar for use with Ancon RT Threaded Couplers is conducted in our factory.

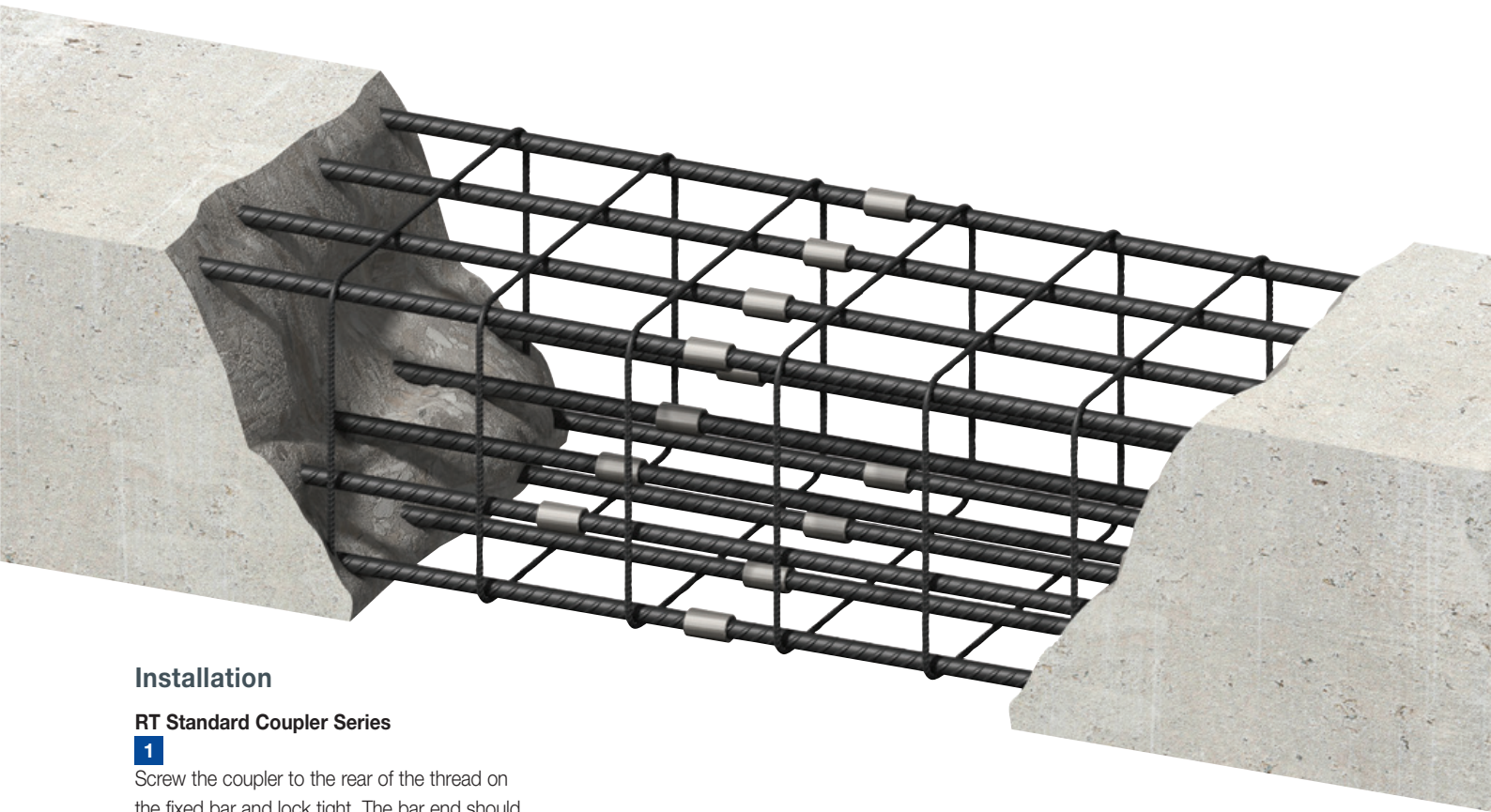

Installation

RT Standard Coupler Series

1

Screw the coupler to the rear of the thread on the fixed bar and lock tight. The bar end should be central within the coupler.

The bar is typically supplied with the coupler already installed. In this case, begin with step 2.

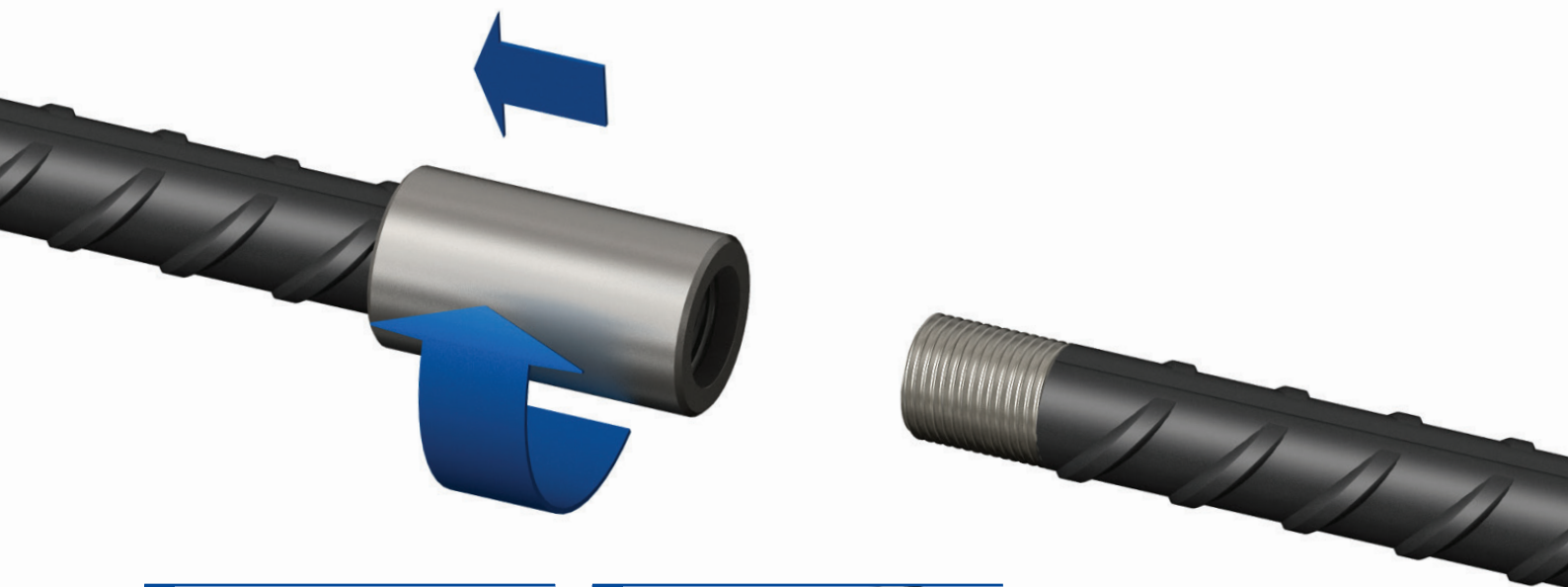

2

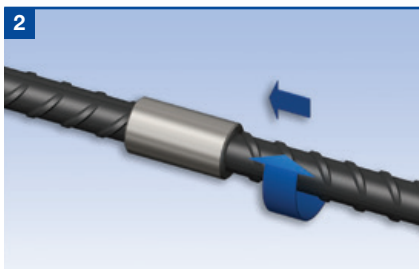

Remove the plastic cap from the coupler. Position and rotate the continuation bar in the coupler.

3

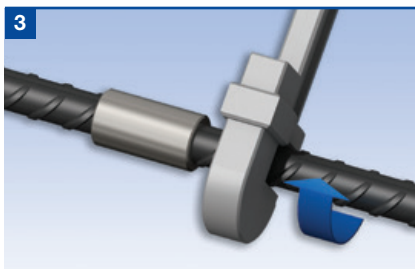

Tighten the joint using a wrench on the continuation bar. After tightening there should be no more than 2-4mm of thread exposed, depending on the diameter of the rebar.

Reinforcing Bar Couplers and Anchors

RT Positional Couplers

The RT Positional coupler is designed for use in applications where neither threaded reinforcing bar can be rotated. Due to its degree of adjustability, where a closer between two fixed bars is required the RT Positional coupler is suitable for use.

RT Positional couplers comprise two standard RT couplers, two threaded reinforcing bars, a positional stud and a locking nut. The positional stud acts as an extended external parallel thread. The locknut is used to secure the connection when the correct degree of adjustability has been achieved. All components, including the locknut, must be tightened using a torque wrench.

Plastic thread protectors are used to prevent damage to the threaded bar ends and the internal threads of the couplers are protected by plastic end caps. A nominal allowance of +25mm should be allowed per threaded bar end for square cutting the bar end.

The Ancon RT Positional Coupler utilises the same thread as the standard RT coupler system. Testing indicates that the RT system can meet strength, slip and cyclic slip performance criteria as stipulated in the Concrete Structures Standard (NZS3101:2006 A3) and the NZTA Bridge Manual.

RT Positional Coupler Dimensions

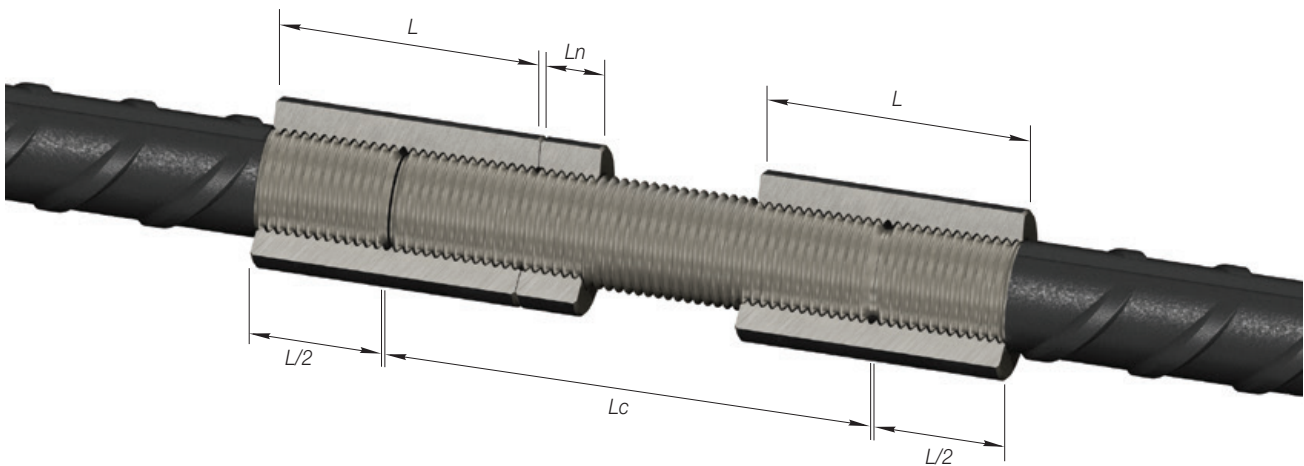

Other connection bars with different lengths (L_c) are available on request.

Bar Diameter (mm)		12	16	20	25	32
External Dia.	d	20	24	30	38	45
Coupler Length	$2t$	34	40	50	54	75
Locknut Length	k	12	12	12	15	15
Thread Size		M13	M17	M21	M26	M33
Thread Pitch		1.75	2.5	2.5	3.5	3.5
Threaded Rod Length	l	125	135	150	160	190
Product Code - Coupler (2x)		RTC12	RTC16	RTC20	RTC25	RTC32
Product Code - Locknut		RTLN12	RTLN16	RTLN20	RTLN25	RTLN32
Product Code - Threaded Rod		RTST12	RTST16	RTST20	RTST25	RTST32
Product Code - Thread		RTT12	RTT16	RTT20	RTT25	RTT32

Note: All dimensions are approximate and subject to change without notice. Contact us for details regarding RT40 and RT50 option. Threading of reinforcing bar for use with Ancon RT Positional Couplers is conducted in our factory.

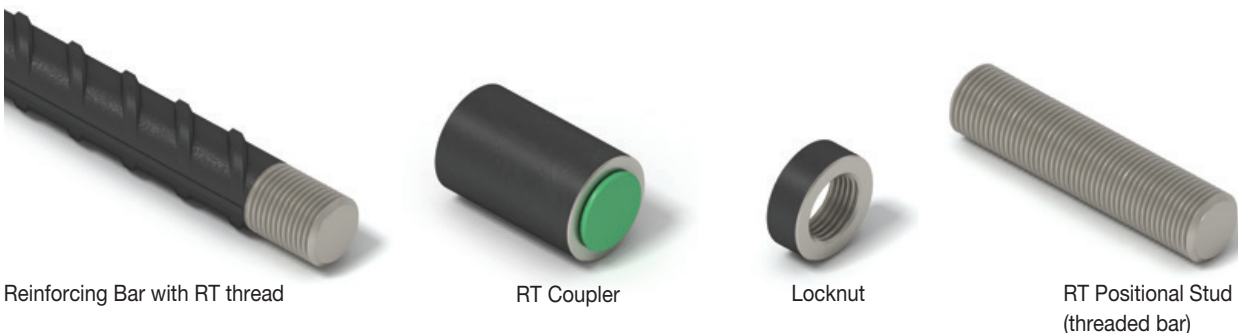

Installation

RT Type P Series

1

Screw one coupler and locknut to the threaded stud.

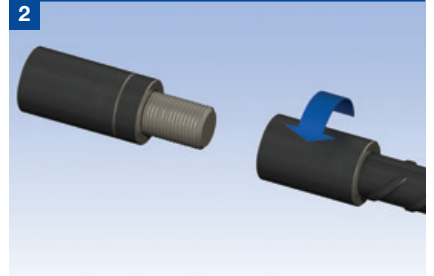
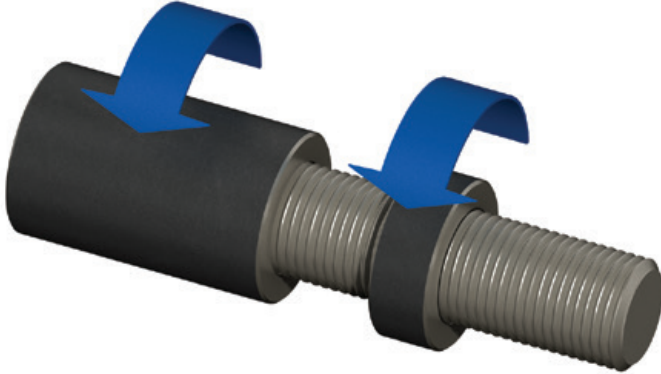

2
Run the coupler to the end of the thread on the fixed bar.

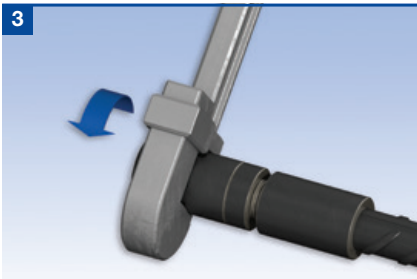

3
Rotate the threaded assembly until the exposed thread fully engages within the coupler. Using a wrench on the coupler, rotate to lock the connection tight.

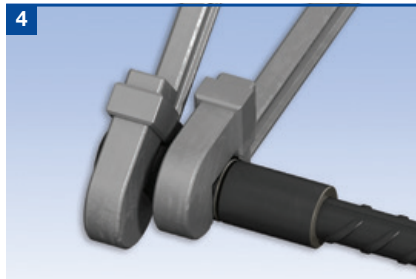

4
Use a second wrench to slacken the coupler/locknut interface.

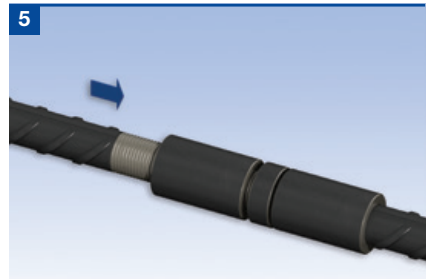

5
Offer the threaded end of the continuation bar to abut the threaded stud.

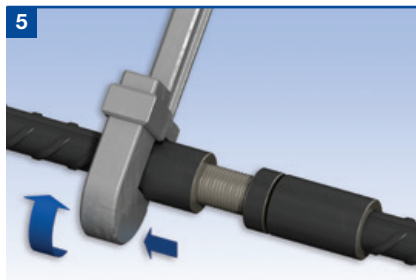

5
Rotate the coupler from the threaded stud to fully engage on the thread on the continuation bar. Lock tight using a wrench.

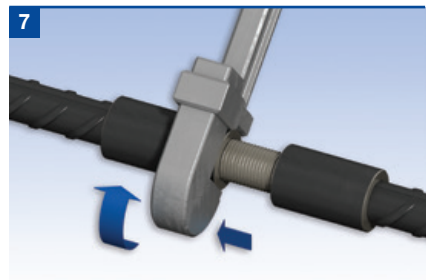

7
Rotate the lock nut and tighten against the continuation bar coupler. Lock tight using a wrench.



Reinforcing Bar Couplers and Anchors

RT Weldable Couplers

The RT Weldable Coupler provides a convenient means of connecting reinforcing bars to structural steel plates or sections. One end has the RT thread form and the other end is prepared for welding to the steel. Ancon RT Weldable Couplers are manufactured from S45C carbon steel according to JIS G 4051: Carbon Steels for Machine Structural Use.

The Ancon RT system has been tested extensively in New Zealand using local and imported grade E, micro-alloyed reinforcing bar. Testing indicates that the RT system can meet strength, slip and cyclic slip performance criteria stipulated in the Concrete Structures Standard (NZS3101:2006 A3) and the NZTA Bridge Manual.

We can provide a standard welding procedure to fit the Ancon RT Weldable Coupler range on request.

RT Weldable Coupler Dimensions

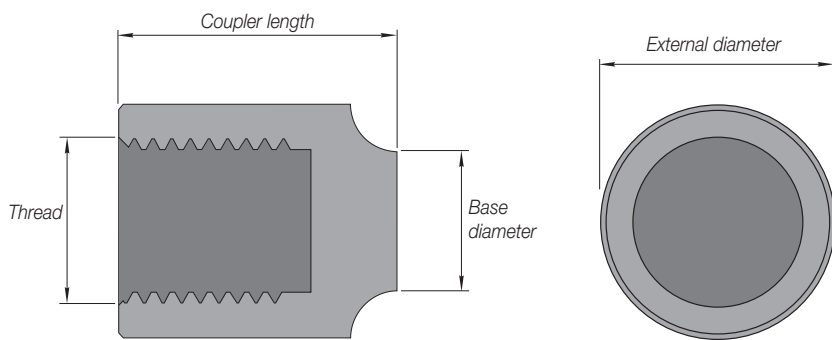
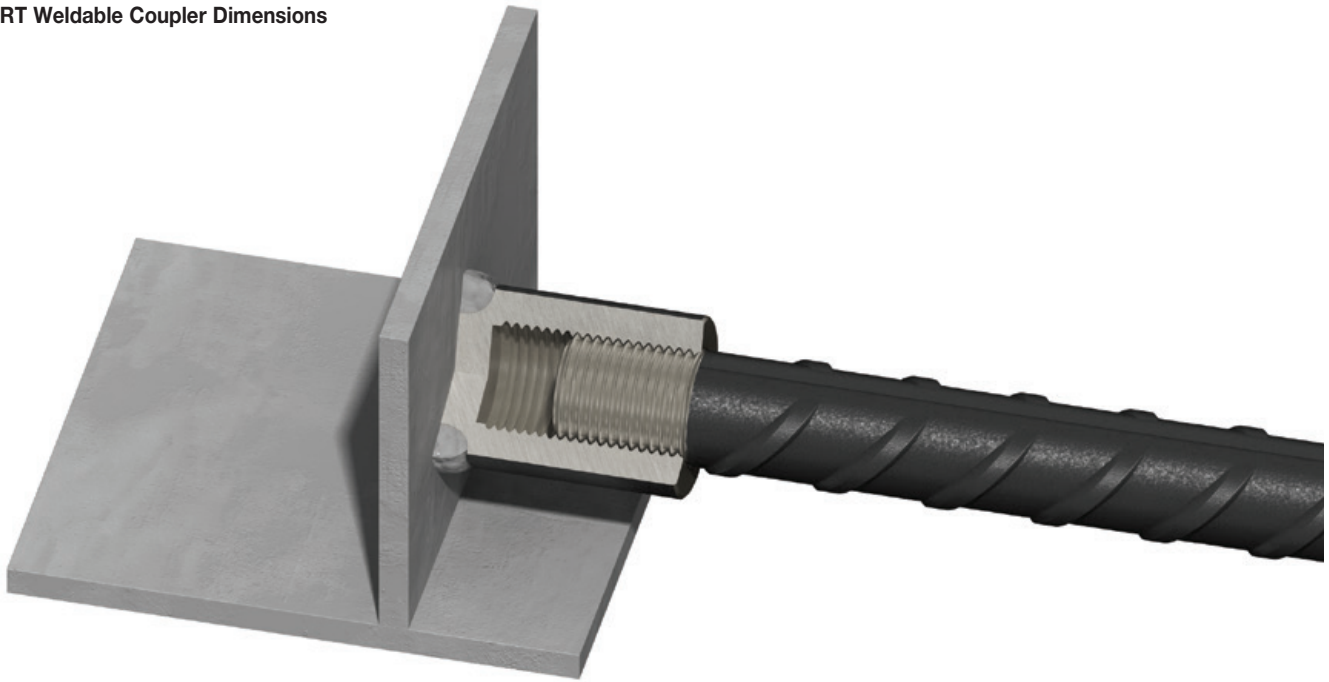

Bar Diameter (mm)	12	16	20	25	32
External Dia. (mm)	28	30	32	40	50
Coupler Length (mm)	36	36	41	48	60
Base Dia. (mm)	18	21	21	23	26
Product Code	RTWC12	RTWC16	RTWC20	RTWC25	RTWC32

Contact us for details regarding RTWC40.

Reinforcing Bar Couplers and Anchors



Dumbbell-Shaped Bar

The Dumbbell-shaped bar system is designed to increase the speed of construction at joints where continuity of reinforcement is required. The system comprises a double-end threaded bar and two RT couplers. The table below shows the minimum length of the system.

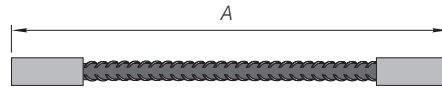

Dumbbell-Shaped Bar Minimum Lengths

Bar Diameter (mm)	12	16	20	25	32	40
Dimension A (mm)	500mm					

Accessories

All threaded bars are delivered with a thread protection cap installed. The caps are colour coded to avoid any mistakes on site. For 12-32mm bars, plastic nailing plates are available in the same colour as the protector cap. The nailing plates are 8mm thick with a 55mm diameter foot. An internal hex shape helps to easily release the nail plate.



Protector Cap



Nail Plates

Bar Diameter (mm)	12	16	20	25	32	40
Protector Cap Colour	Light Blue	Brown	White	Grey	Black	Dark Green
Nail Plate	✓	✓	✓	✓	✓	-

Coupled Cogged Bars

The compact size of Ancon RT threaded couplers makes them ideal for use with cogged bars. Critical dimensions are given in the table.

The bend radius assumed is 5D pin diameter for 12mm to 20mm bars and 6D pin diameter for 25mm to 40mm, where D is the bar diameter.

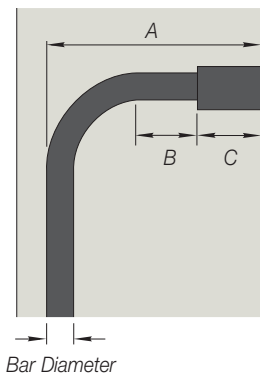

RT System Minimum Cogged Lengths

Bar Diameter (mm)	12	16	20	25	32	40
Dimension A (mm)	98	120	152	197	360	427
Dimension B (mm)	22	24	32	43	157	177
Coupler Length C (mm)	34	40	50	54	75	90

Continuation Bar

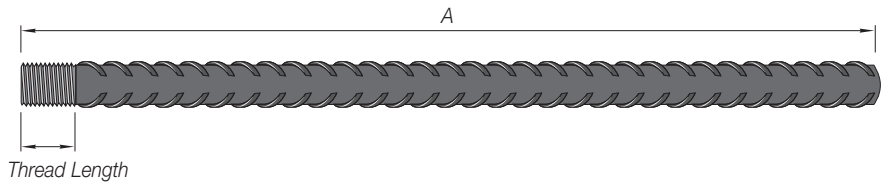

Stocked Continuation Bar Details

Bar Diameter (mm)	12	16	20	25	32	40
Dimension A (mm)	1200*	1200*	-	-	-	-
Thread Length (mm)	17	20	25	27	37.5	45

*Contact us for availability and details of other stocked sizes.

RT Headed Anchors

RT Headed Anchors create an anchorage in the concrete, replacing the need for coggled or hooked bar ends. They can simplify scheduling and bar placement, and reduce congestion in the concrete.

Designed for use with common reinforcing bar diameters, the Ancon RT headed anchor is essentially an oversized threaded coupler capable of carrying the tension load of the bar when it bears against the concrete in which it is cast.

Like the threaded coupler, the RT headed anchor attaches to reinforcing bar that has been parallel-threaded on an Ancon RT threading machine.

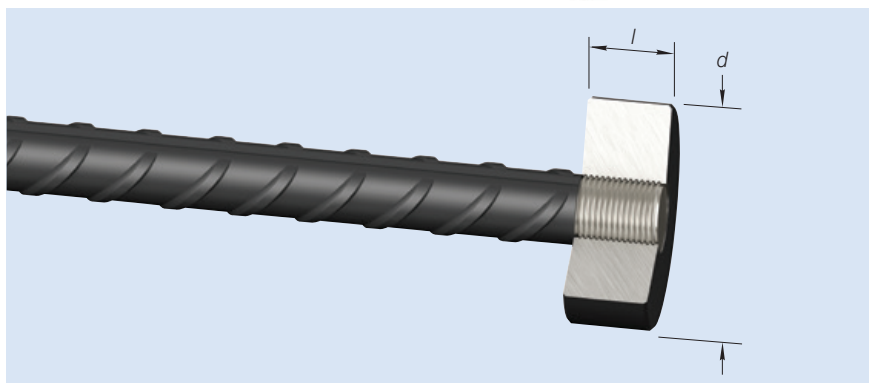
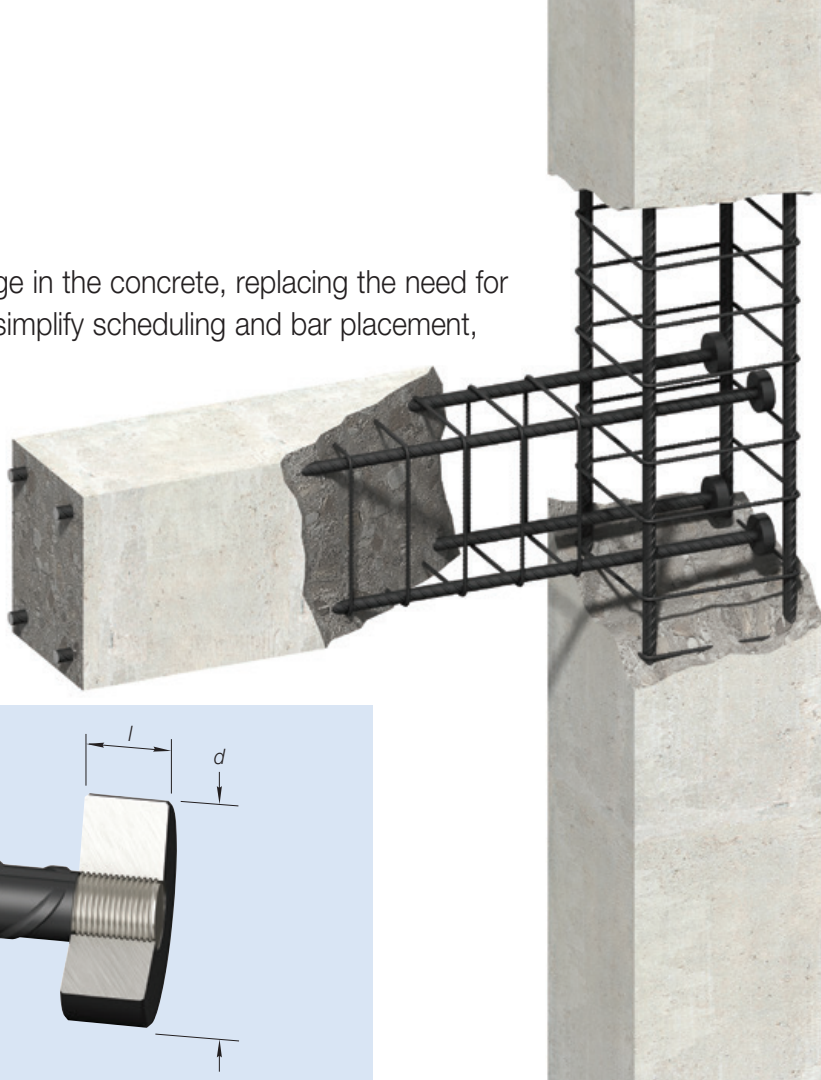

Dimensions and Specifications

Bar Diameter (mm)	12	16	20	25	32	40
External Dia. (mm) <i>d</i>	38	50	64	76	102	127
Anchor Length (mm) <i>l</i>	17	20	25	27	37	45
Thread Size	M13	M17	M21	M26	M33	M41
Thread Pitch	1.75	2.5	2.5	3.5	3.5	3.5
Specification / Product Code	RTHA12	RTHA16	RTHA20	RTHA25	RTHA32	RTHA40

RT KSN Anchors

Ancon RT KSN Anchors, in combination with RT parallel-threaded reinforcing bars, simplify concrete slab-to-wall construction joints when compared to traditional methods.

This quicker, easier and above all, safer operation, eliminates the need for on-site bar straightening and the drilling of formwork or concrete. The system replaces coggled or hooked bar ends, thereby simplifying bar scheduling and minimising congestion in the wall.

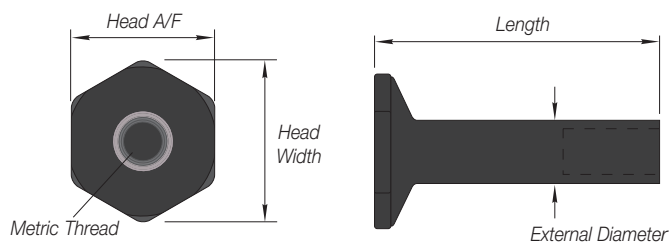

Dimensions and Specifications

Anchor Ref.	Anchor Length (mm)	Nominal External Diameter (mm)	Metric Thread	Nominal Head Width (mm)	Nominal Head A/F (mm)
RT KSN12S	115				
RT KSN12M	150	22	M13 x 1.75	46	40
RT KSN16S	130				
RT KSN16M	160	28	M17 x 2.5	61	53
RT KSN16L	190				
RT KSN20S	150				
RT KSN20M	190	32	M21 x 2.5	75	65
RT KSN20L	230				



Reinforcing Bar Couplers and Anchors

MBT Mechanically Bolted Couplers

The MBT range of couplers provides a cost-effective method of joining reinforcing bars, particularly when the fixed bar is already in place and there is insufficient space for a hydraulic swaging press.

They are easy to install and achieve failure loads higher than 110% of the characteristic yield strength of grade 500 reinforcing bar. Neither bar end preparation to form threads, nor bar rotation are required. MBT couplers can also be used to join imperial, plain round or deformed reinforcing bars.

The bar ends are supported within the coupler by two serrated saddles, and as the lockshear bolts are tightened, the conical ends embed themselves into the bar. As this happens the serrated saddles bite into both the bar and the shell of the coupler. The lockshear bolts of couplers up to and including the MBT20C can be tightened using a ratchet wrench. For larger couplers a nut runner is recommended.

In all cases heavy duty sockets should be used. When the pre-determined tightening torque for the bolts is reached, the heads shear off leaving the top of the installed bolt slightly proud of the coupler. This provides an instant visual check of correct installation.

Note: Impact tools should not be used to tighten lockshear bolts.

Testing & Approvals

Full destructive tests are carried out on selected couplers from our stocks. MBT couplers are manufactured to a strict quality regime accredited to ISO 9001.

Testing conducted in New Zealand using grade E, micro-alloyed reinforcing bar demonstrates that connections using MBT couplers, in common 12-20mm sizes, exceed the tensile strength of the reinforcement bar. MBT in these sizes comply with NZS3101:2006 A3 and NZTA Bridge Manual requirements for seismicity, slip and resistance to brittle fracture. Contact us to request a copy of the full New Zealand testing details.

Connections, with sizes 25 to 40mm MBT couplers, provide a minimum tensile strength close to the tensile strength of the reinforcement bar.

MBT couplers have also been tested to show compliance with the following international design codes:- ACI 318 and BS8597.

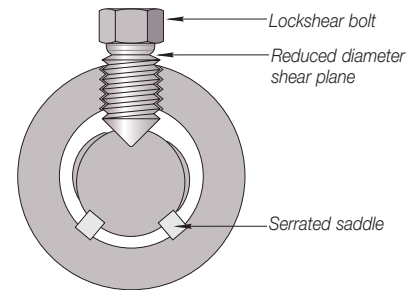

Section showing the embedment of the lockshear bolts and saddles into the bar and the shell of the coupler.



MBT ET Series

The MBT ET series of couplers is used to connect reinforcing bars of the same size.

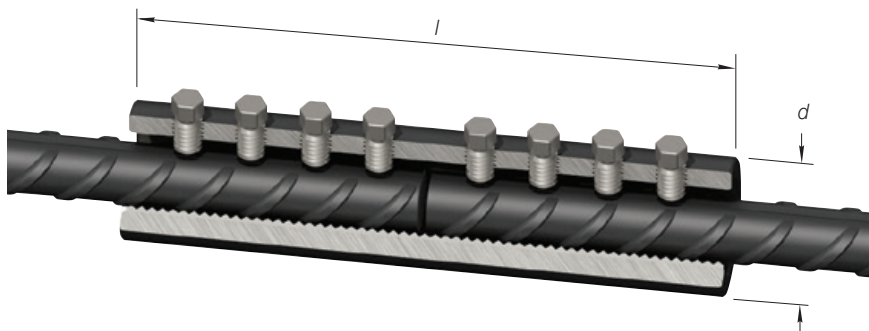

MBT ET Series Dimensions

Bar Diameter (mm)	12	16	20	25	32	40
External Dia. d	33.4	42.2	48.3	54.0	71.0	81.0
Total Length l	140	160	204	258	312	484
Socket Size A/F (ins)	1/2	1/2	1/2	5/8	5/8	3/4
No. of Bolts	6	6	8	8	10	14
Approx Weight (kg)	0.72	1.25	1.96	3.00	6.50	11.3
Torque (Nm)	55	108	108	275	360	525
Part No.	MBT12C	MBT16C	MBT20C	MBT25C	MBT32C	MBT40C

Note: MBT couplers for 50mm reinforcement bars are also available. Contact us for details.

Installation

MBT ET Series

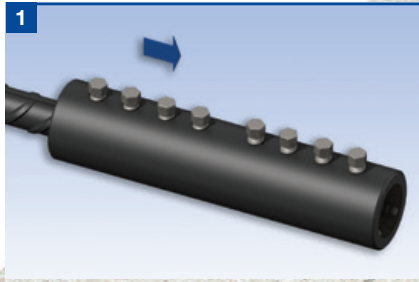

1 Place the coupler over the end of the bar to half the coupler length +/- 6mm and finger tighten the lockshear bolts onto the bar. Check the alignment and make any necessary adjustments.

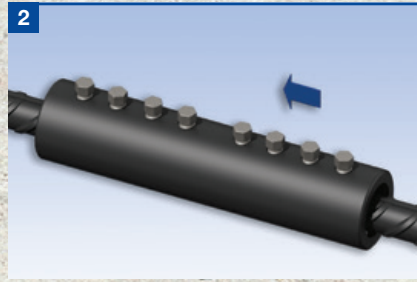

2 Place the other bar end into the coupler until it pushes up against the first bar and finger tighten the remaining lockshear bolts. Check alignment and make any adjustments.

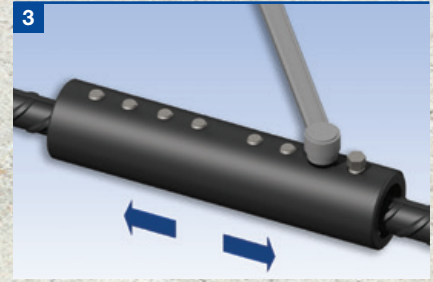

3 On one half of the coupler, starting from the centre and working outwards, partly tighten the lockshear bolts using either a ratchet wrench or a nut runner as appropriate. Do not use impact tools. Repeat again, this time fully tightening the lockshear bolts until the bolt heads shear off.

Repeat the above for the other half of the coupler.



Reinforcing Bar Couplers and Anchors



Repair and Remedial Work

For applications involving replacement of corroded or damaged bars, the replacement bar is cut approximately 5mm shorter to allow clearance for insertion between the sound ends of the original bars. MBT couplers are pushed fully over both ends of the replacement bar and temporarily held in position.

The replacement bar is then correctly positioned and the couplers moved to a previously marked position on the existing bars indicating half the length of the coupler. The lockshear bolts are tightened to complete the installation.

MBT Transition Series

The MBT Transition series of couplers provides an effective solution for connecting bars of different diameters.

Transition couplers offer all the same benefits as the MBT ET series. They can be installed without any preparation to the bar ends and without any need to rotate bars. The coupler can be rotated to allow access to the bolts for tightening with either a ratchet wrench or a nut runner. In all cases heavy duty sockets should be used. Transition couplers are non-standard and are made to order.

Note: Impact tools should not be used to tighten lockshear bolts.

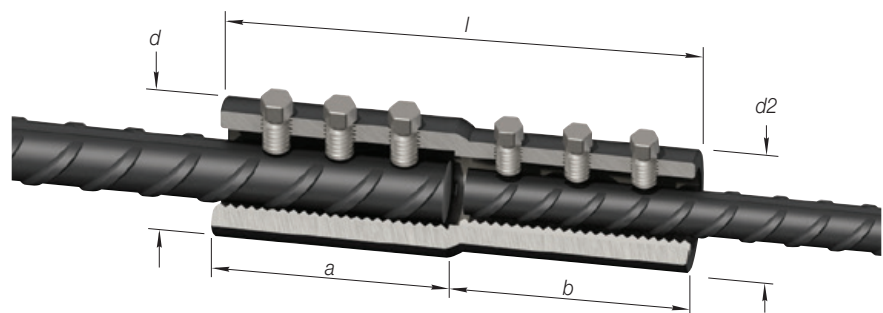

MBT Transition Series Dimensions

Bar Diameter (mm)	20/12	20/16	25/16	25/20	32/20	32/25
External Dia. d	48.3	48.3	54	54	71	71
External Dia. $d2$	33.4	48.3	42.2	54	48.3	54
Total Length l	150	160	155	180	177	231
Individual Length $a:b$	80:70	80:80	75:80	90:90	75:102	102:129
Socket Size A/V (ins) $a:b$	1/2:1/2	1/2:1/2	5/8:1/2	5/8:1/2	5/8:1/2	5/8:5/8
No. of Bolts $a:b$	3:3	3:3	2:3	3:3	2:4	3:4
Approx Weight (kg)	1.13	1.56	1.51	2.23	2.55	3.70
Torque (Nm)	108:55	108:108	275:108	275:108	360:108	360:275
Part No.	MBT20/12C	MBT20/16C	MBT25/16C	MBT25/20C	MBT32/20C	MBT32/25C

Notes: These items are not stocked in New Zealand. Please enquire for lead times. ET40/32 also available. Contact us for details.



Installation

MBT Transition Series

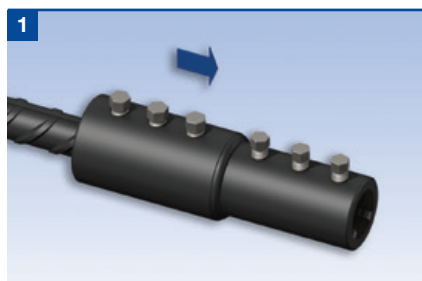

Place the coupler over the end of the bar to the appropriate depth +/- 6mm and finger tighten the lockshear bolts onto the bar. Check the alignment and make any necessary adjustments.

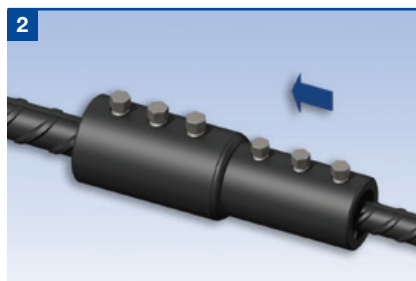

Place the other bar end into the coupler until it pushes up against the first bar and finger tighten the remaining lockshear bolts. Check alignment and make any adjustments.

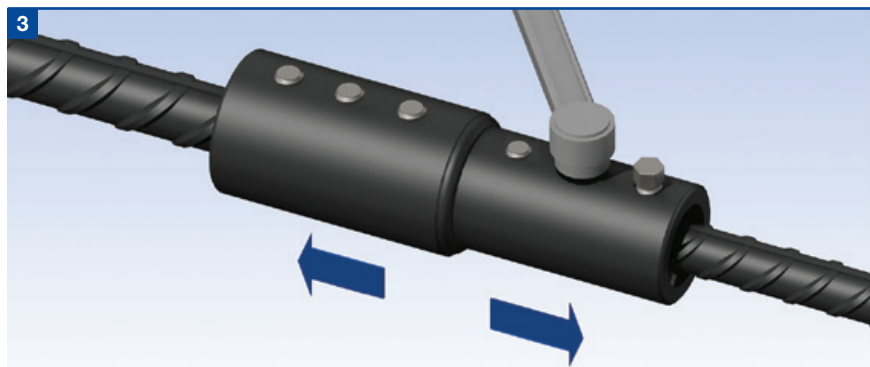

On one half of the coupler, starting from the centre and working outwards, partly tighten the lockshear bolts using either a ratchet wrench or a nut runner as appropriate. Do not use impact tools. Repeat again, this time fully tightening the lockshear bolts until the bolt heads shear off. Repeat the above for the other half of the coupler.

Reinforcing Bar Couplers and Anchors



MBT Headed Anchors

MBT Headed Anchors are designed to provide dead end embedment for bars in concrete. This helps to reduce congestion and simplify the placement of rebars by removing the need for hooked ends.

The Anchor comprises half an MBT coupler with a plate welded to one end which carries the full tension load of the bar when it is bearing against the concrete. It also has the added advantage of requiring no special bar end preparation. The performance of MBT Headed Anchors is in line with the performance of MBT couplers (see page 12).

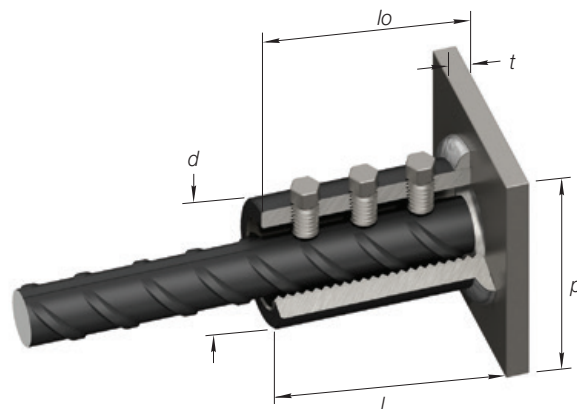

MBT Headed Anchor Dimensions

Bar Diameter (mm)	12	16	20	25	32	40
External Diameter d	33.4	42.2	48.3	54.0	71.0	81.0
Coupler Length l	75	82	104	129	156	247
Total Length l_o	85	92	114	139	171	262
Plate Thickness t	10	10	10	10	15	15
Plate w x h p	70	80	90	100	130	150
Socket Size A/F (ins)	1/2	1/2	1/2	5/8	5/8	3/4
No of Bolts	3	3	4	4	5	7
Approx Weight (kg)	0.74	1.07	1.58	2.29	4.72	8.30
Torque (Nm)	55	108	108	275	360	525
Part No.	MBTHA12H	MBTHA16H	MBTHA20H	MBTHA25H	MBTHA32H	MBTHA40H

Note: Minimum compressive strength of concrete 25MPa. Other sizes are available on request.



Nut Runner

To facilitate the installation of MBT couplers and anchors, Ancon Nut Runners are available for purchase or hire. The smooth continuous action of the nut runner prevents the early shearing of the lockshear bolts and damage to threads. It is supplied with specially hardened heavy duty sockets. Please contact us for details.



Note: Impact tools should not be used to tighten lockshear bolts. In all cases heavy duty sockets should be used.

Other Products

Lindapter® Steel Connection Systems

Leviat is an authorised Lindapter distributor and supplies this range of premium steelwork fixings to a variety of industries for connecting structural or secondary steel sections. Lindapter's products are designed to avoid drilling or welding steel on-site and offer a faster, safer alternative to other connection techniques. Solutions include the Girder Clamp for connecting steel beams together, the Hollo-Bolt® expansion bolt for Structural Hollow Sections (SHS) and the Grate-Fast® for securing steel flooring.



Shear Load Connectors

Ancon DSD and ESD Shear Load Connectors are used to transfer shear across expansion and contraction joints in concrete. They are more effective at transferring load and allowing movement to take place than standard dowels, and can be used to eliminate double columns at structural movement joints in buildings. A 'Lockable' dowel is also available for temporary movement joints in post-tensioned concrete frames.



Lifting Systems

EdjPro is ideal for lifting thin factory cast panels where a high finish is required. Unilift Locking Klaws are strong, safe, lightweight clutches that suit all spherical head lifting anchors. LinkPro lifting loops facilitate the safe handling of units such as bridge and shell beams.



Masonry Support Systems

Masonry cladding on concrete or steel frames is normally supported from stainless steel support systems. Ancon MDC Systems create a continuous angle to support the outer leaf of masonry. Ancon Individual Brackets support masonry features such as curves and arches.

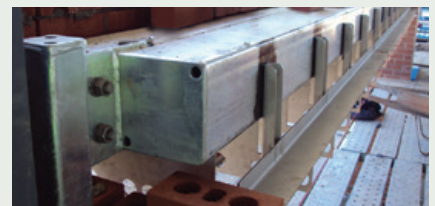

Channel and Bolt Fixings

Leviat offers a wide range of channels and bolts in order to fix stainless steel masonry support, restraints and windposts to structural frames. Cast-in channels and expansion bolts are used for fixing to the edges of concrete floors and beams. A range of stainless steel set screws and self-drill self-tap screws are designed to fix to steel frames.



Special Fabrications

Leviat is an ASSDA accredited specialist fabricator and has a wealth of experience in working with a variety of material grades. High integrity steel components are supplied to a wide range of industries including Civil Engineering, Building, Infrastructure, Water Treatment, Nuclear and Mining.



© Thiess - Energy Australia

Worldwide contacts for Leviat:

Australia

Leviat
98 Kurrajong Avenue,
Mount Druitt Sydney, NSW 2770
Tel: +61 - 2 8808 3100
Email: info.au@leviat.com

Austria

Leviat
Leonard-Bernstein-Str. 10
Saturn Tower, 1220 Wien
Tel: +43 - 1 - 259 6770
Email: info.at@leviat.com

Belgium

Leviat
Industrielaan 2
1740 Ternat
Tel: +32 - 2 - 582 29 45
Email: info.be@leviat.com

China

Leviat
Room 601 Tower D, Vantone Centre
No. A6 Chao Yang Men Wai Street
Chaoyang District
Beijing · P.R. China 100020
Tel: +86 - 10 5907 3200
Email: info.cn@leviat.com

Czech Republic

Leviat
Business Center Šafránková
Šafránková 1238/1
155 00 Praha 5
Tel: +420 - 311 - 690 060
Email: info.cz@leviat.com

Finland

Leviat
Vädursgatan 5
412 50 Göteborg / Sweden
Tel: +358 (0)10 6338781
Email: info.fi@leviat.com

France

Leviat
6, Rue de Cabanis
FR 31240 L'Union
Toulouse
Tel: +33 - 5 - 34 25 54 82
Email: info.fr@leviat.com

Germany

Leviat
Liebigstrasse 14
40764 Langenfeld
Tel: +49 - 2173 - 970 - 0
Email: info.de@leviat.com

India

Leviat
309, 3rd Floor, Orion Business Park
Ghodbunder Road, Kapurbawdi,
Thane West, Thane,
Maharashtra 400607
Tel: +91 - 22 2589 2032
Email: info.in@leviat.com

Italy

Leviat
Via F.lli Bronzetti 28
24124 Bergamo
Tel: +39 - 035 - 0760711
Email: info.it@leviat.com

Malaysia

Leviat
28 Jalan Anggerik Mokara 31/59
Kota Kemuning, 40460 Shah Alam
Selangor
Tel: +603 - 5122 4182
Email: info.my@leviat.com

Netherlands

Leviat
Oostermaat 3
7623 CS Borne
Tel: +31 - 74 - 267 14 49
Email: info.nl@leviat.com

New Zealand

Leviat
2/19 Nuttall Drive, Hillsborough,
Christchurch 8022
Tel: +64 - 3 376 5205
Email: info.nz@leviat.com

Norway

Leviat
Vestre Svanholmen 5
4313 Sandnes
Tel: +47 - 51 82 34 00
Email: info.no@leviat.com

Philippines

Leviat
2933 Regus, Joy Nostalg,
ADB Avenue
Ortigas Center
Pasig City
Tel: +63 - 2 7957 6381
Email: info.ph@leviat.com

Poland

Leviat
Ul. Obornicka 287
60-691 Poznan
Tel: +48 - 61 - 622 14 14
Email: info.pl@leviat.com

Singapore

Leviat
14 Benoi Crescent
Singapore 629977
Tel: +65 - 6266 6802
Email: info.sg@leviat.com

Spain

Leviat
Polígono Industrial Santa Ana
c/ Ignacio Zuloaga, 20
28522 Rivas-Vaciamadrid
Tel: +34 - 91 632 18 40
Email: info.es@leviat.com

Sweden

Leviat
Vädursgatan 5
412 50 Göteborg
Tel: +46 - 31 - 98 58 00
Email: info.se@leviat.com

Switzerland

Leviat
Grenzstrasse 24
3250 Lyss
Tel: +41 - 31 750 3030
Email: info.ch@leviat.com

United Kingdom

Leviat
President Way, President Park,
Sheffield, S4 7UR
Tel: +44 - 114 275 5224
Email: info.uk@leviat.com

United States of America

Leviat
6467 S Falkenburg Rd.
Riverview, FL 33578
Tel: (800) 423-9140
Email: info.us@leviat.us

For countries not listed

Email: info@leviat.com

Leviat.com

Notes regarding this catalogue

© Protected by copyright. The construction applications and details provided in this publication are indicative only. In every case, project working details should be entrusted to appropriately qualified and experienced persons. Whilst every care has been exercised in the preparation of this publication to ensure that any advice, recommendations or information is accurate, no liability or responsibility of any kind is accepted by Leviat for inaccuracies or printing errors. Technical and design changes are reserved. With a policy of continuous product development, Leviat reserves the right to modify product design and specification at any time.

For more information on the following products, please contact:

**Masonry, Structural and
Precast Concrete products:**

+64 (0) 3 376 5205
info.ancon.nz@leviat.com
Ancon.co.nz

**Remedial Masonry
products:**

+64 (0) 3 376 5205
info.helifix.nz@leviat.com
Helifix.co.nz

General Enquiries

+64 (0) 3 376 5205
Leviat.com

Sales Offices and Production

North Island:

246D James Fletcher Drive
Otahuhu
Auckland 2024
New Zealand

South Island:

2/19 Nuttall Drive
Hillsborough
Christchurch 8022
New Zealand

Leviat.com

Leviat[®]
A CRH COMPANY

Imagine. Model. Make.

Leviat.com