



PRE-TENSIONING GRIPS TECHNICAL BROADSHEET

CCL PRE-TENSIONING RANGE

OPEN GRIPS BARRELS AND WEDGES

Open grips should only be used at the stressing end (live end) of the bed with a hydraulic jack incorporating power lock-off. If power lock-off is not available then spring-loaded grips should be used. The wedges are made up of two segments for use with wire and three for use with strand.

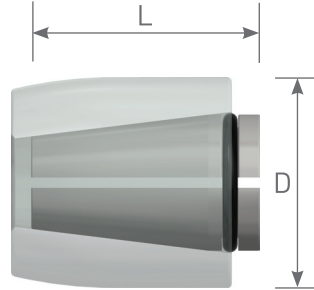

Dia. Wire/Strand	3	4	5	6	7	7s	8	8s	9.6	9.6s	11	13	15
O/DIA (D) mm	24	24	24	24	24	30	35	30	35	30	41	44	50
LENGTH (L) mm	26	26	26	26	26	33	40	33	40	33	43	51	54
MAX LOAD kN	55	55	55	55	55	80	80	80	80	80	124	167	246
WEIGHT kg	0.11	0.11	0.10	0.10	0.10	0.23	0.27	0.23	0.26	0.23	0.41	0.54	0.81
BARREL CODE	605510	605510	605510	605510	605510	605108	604101	605108	604101	605108	604103	604104	604145
WEDGE CODE	605700	605701	605703	605704	605705	109157	604201	605227	604202	605228	604203	604204	604225
O RING	605715	605715	605715	605715	605715	604265	604248	604265	604248	604265	604248	604249	604261

The maximum barrel loads referenced are based on 80% of the strand/wire characteristic breaking load.

SLA SPRING-LOADED ANCHORS

Spring-loaded anchors or grips should always be used at the non-stressing end of the bed. They should also be used at the stressing end where jacks without power lock-off are being used.

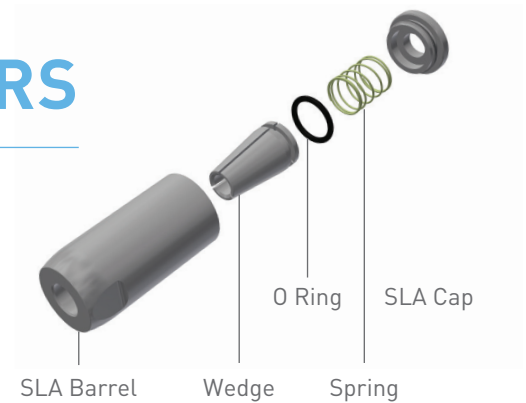
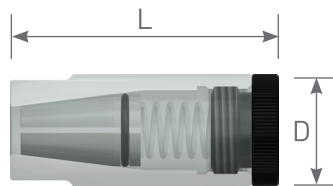

Dia. Wire/Strand	3	4	5	6	7	7s	8	8s	9.6	9.6s	13	15
O/DIA (D) mm	24	24	24	24	24	30	35	30	35	30	44	50
LENGTH (L) mm	59	59	59	59	59	67	78	67	78	67	97	103
MAX LOAD kN	55	55	55	55	55	80	80	80	80	80	167	246
WEIGHT kg	0.16	0.16	0.16	0.16	0.16	0.26	0.37	0.26	0.37	0.26	0.69	0.99
SPRING CODE	603421	603421	603421	603421	603421	605404	604416	605404	604416	605404	604419	604435
CAP CODE	605320	605320	605320	605320	605320	605315	604316	605315	604316	605315	604317	604320
BARREL CODE	605520	605520	605520	605520	605520	605146	604143	605146	604143	605146	604141	604140
WEDGE CODE	605700	605701	605703	605704	605705	109157	604201	605227	604202	605228	604204	604225
O RING	605715	605715	605715	605715	605715	604265	604248	604265	604248	604265	604249	604261
COMPLETE GRIP	605600	605601	605603	605604	605605	605170	604041	605150	604017	605160	604044	604073

BAYONET GRIP

Bayonet grips are similar to SLA grips but have a quick release twist cap. They should always be used at the non-stressing end of the bed and should also be used at the stressing end where jacks without power lock-off are being used.

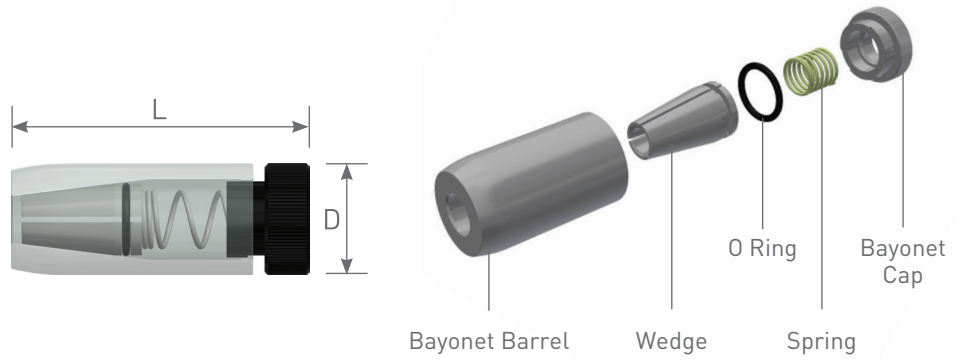

Dia. Wire/Strand	3	4	5	6	7	8	9.6	13	15
O/DIA (D) mm	24	24	24	24	24	35	35	44	50
LENGTH (L) mm	66	66	66	66	66	84	84	88	109
MAX LOAD kN	55	55	55	55	55	80	80	167	246
WEIGHT kg	0.17	0.17	0.17	0.17	0.17	0.45	0.45	0.79	1.15
SPRING CODE	603421	603421	603421	603421	603421	604415	604415	604424	604435
CAP CODE	605325	605325	605325	605325	605325	604325	604325	604328	604322
BARREL CODE	605515	605515	605515	605515	605515	604132	604132	604124	604129
WEDGE CODE	605700	605701	605703	605704	605705	604201	604202	604204	604225
O RING	605715	605715	605715	605715	605715	604248	604248	604249	604261
COMPLETE GRIP	605610	605611	605613	605614	605615	604081	604068	604024	604049

The maximum barrel loads referenced are based on 80% of the strand/wire characteristic breaking load.

DEJ DOUBLE-ENDED JOINT

DEJ/DEJ reducers can be used to connect wire/strand together mid-span. Where a reducing joint is used, the prestressing force should never exceed 80% of the manufacturer's specified minimum breaking load for the smallest wire or strand being used.

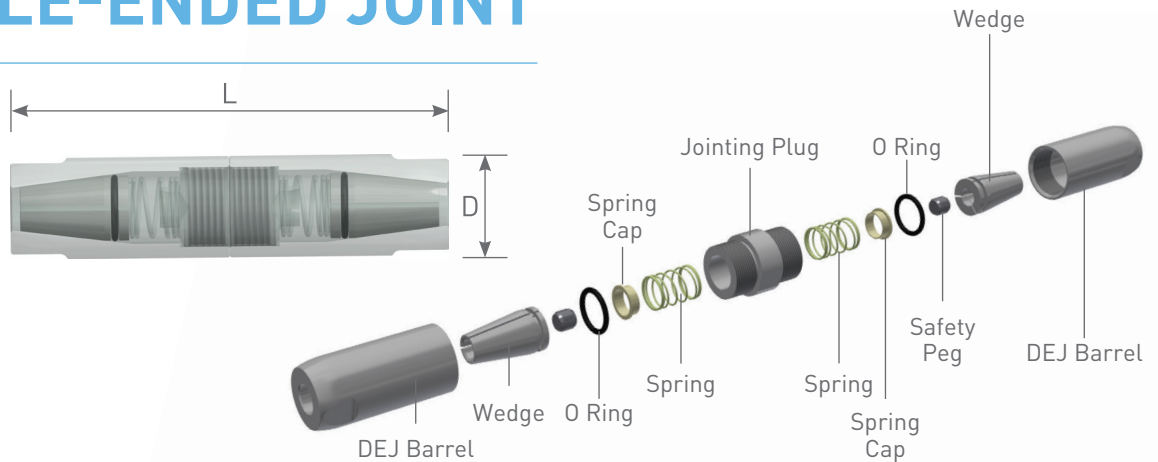

Dia. Wire/Strand	3	4	5	6	7	7s	8	8s	9.6	9.6s	13	15
O/DIA (D) mm	24	24	24	24	24	30	35	30	35	30	44	50
LENGTH (L) mm	106	106	106	106	106	140	157	140	157	140	198	210
MAX LOAD kN	55	55	55	55	55	80	80	80	80	80	167	246
WEIGHT kg	0.33	0.33	0.33	0.32	0.32	0.62	0.94	0.62	0.94	0.62	1.76	2.46
SPRING CODE	603422	603422	603422	603422	603422	605404	604401	605404	604401	605404	604424	604424
SPRING CAP CODE	-	-	-	-	-	605539	604539	605539	604539	605539	604537	604537
BARREL CODE	605520	605520	605520	605520	605520	605146	604143	605146	604143	605146	604141	604140
WEDGE CODE	605700	605701	605703	605704	605705	109157	604201	605227	604202	605228	604204	604225
PLUG CODE	605340	605340	605340	605340	605340	605370	604353	605370	604353	605370	604339	604338
O RING	605715	605715	605715	605715	605715	604265	604248	604265	604248	604265	604249	604261
SAFETY PLUG CODE	-	-	-	-	-	-	604364	604364	604363	604363	604361	604360
COMPLETE GRIP	605650	605651	605653	605654	605655	605171	604067	605151	604066	605161	604064	604062

The maximum barrel loads referenced are based on 80% of the strand/wire characteristic breaking load.

GRIP ACCESSORIES

The correct lubrication of jack wedges is essential to prolong life and ease dismantling of the grip after stressing. Two lubrication products are available. A molybdenum-based release agent comes in aerosol form and dries to form a hard coating on the wedge around ten minutes after application. Also available is Super Dippy lubricant which remains in a fluid state after being liberally applied to the wedge components of the grip.

Shock detensioning can cause undue stresses on the grips resulting in damage that will significantly reduce the working life. CCL provides detensioning kits to allow the safe detensioning of tendons.

A range of brushes is available for the cleaning of wedges and barrels. These are designed to fit standard drill chucks. The barrel brushes are specially tapered to effectively clean the inside body of the barrel.

CCL grip release tools are precision machined alloy products used to aid the release of wedges from barrels. The tool is inserted into the bearing end of the barrel until in contact with the wedge. A sharp hammer blow is then delivered to the tool to break the contact between the wedge and barrel without damaging either component.



PRODUCT SELECTION

Dia. Wire/Strand	3	4	5	6	7	7s	8	8s	9.6	9.6s	11	13	15
OPEN WEDGE	605700	605701	605703	605704	605705	109157	604201	605227	604202	605228	604203	604204	604225
OPEN BARREL	605510	605510	605510	605510	605510	605108	604101	605108	604101	605108	604103	604104	604145
O RING	605715	605715	605715	605715	605715	604265	604248	604265	604248	604265	604248	604249	604261
SLA GRIP	605600	605601	605603	605604	605605	605170	604041	605150	604017	605160	-	604044	604073
BAYONET GRIP	605610	605611	605613	605614	605615	-	604081	-	604068	-	-	604024	604049
DEJ	605650	605651	605653	605654	605655	605171	604067	605151	604066	605161	-	604064	604062
JACK SHORT STROKE	105400	105400	105401	105401	105401	105404	106400	106405	106401	106404	106402	106403	107401
JACK LONG STROKE	-	-	-	-	-	-	106401	106415	106411	106414	106412	106413	107411
JACK WEDGE	101028	101028	101035	101035	101035	101035	101004	101004	101003	101003	101002	101001	101013
JACK NOSE	105015	105015	105015	105015	105015	105085	106030	106210	106030	106210	106031	106029	107016
TOOL KIT	102120	102120	102120	102120	102120	102120	102126	102126	102126	102126	102126	102126	102100
PUMP SRX*	171002	171002	171002	171002	171002	171002	171002	171002	171002	171002	171002	171002	-
PUMP SR3000*	170102	170102	170102	170102	170102	170102	170102	170102	170102	170102	170102	170102	170102

*380/415V version. Other voltages are available.

SAFE WORKING PRACTICES

- The wire/strand must be cut square and ragged edges removed.
- Kinked or deformed strand must never be used for stressing.
- In the general interests of safety, grips holding wire/strand under load should be sheltered with material of adequate strength to prevent injury or damage in the event of a wire/strand failure.
- Before stressing, the dead end should be sheltered.
- The live end should be sheltered immediately after stressing.
- Double ended joints (DEJs) should be sheltered before stressing and whilst under load.
- During the tensioning process all non-essential personnel should leave the stressing area.
- Stressing should be carried out in a sequence to ensure that the jack operator never stands behind a stressed or unsheltered wire or strand during stressing.
- Operators should not stand in line with any stressed wire/strand or stand directly behind the jack during tensioning.
- Never walk on stressed strands.
- Protect open stressing beds with chains or other substantial and suitably constructed guards to protect persons from injury due to sudden wire/strand release.
- Signs warning of the potential danger should be placed around stressed beds.
- Any load/elongation remaining in the wire/strand must be removed in a controlled manner prior to cutting or burning the wire/strand to remove the grips.
- Consult CCL before attempting any prestressing or load/elongation removal procedure that may affect the performance of the grips.



Regional Headquarters

Americas

8296 Sherwick Court,
Jessup, MD 20794,
United States

T: +1 (301) 490 8427

E: cclus@cclint.com

Europe

Unit 8, Millennium Drive,
Leeds, LS11 5BP,
United Kingdom

T: +44 (0) 113 270 1221

E: cclgb@cclint.com

Gulf

Detroit House Building, Flat No. 201,
Motorcity, Dubai,
United Arab Emirates

T: +971 (4) 454 23 42

E: cclgulf@cclint.com

F: +971 (4) 454 23 43

MENA/Africa

Derviche Haddad Building,
Zouk Mosbeh, Beirut,
Lebanon

T: +961 (09) 22 60 44

E: cclsg@cclint.com

F: +961 (09) 22 60 77



The specifications, information and performance of the products manufactured by CCL and featured in this publication are presented in good faith and believed to be correct. Details may be changed without notice. CCL makes no representations or warranties as to the completeness or accuracy of the information. Information is supplied upon the condition that the persons receiving same will make their own determination as to its suitability for their purposes prior to use. In no event will CCL be responsible for damages of any nature whatsoever resulting from the use of, or reliance upon, information contained in this document. CCL accepts no liability for any errors or omissions therein.

CCL.11/2018